

# Pipe Flow

Gary D. Beckfeld, M.S.E., P.E.

## COURSE CONTENT

### 1. Fluid and Flow Classifications

Fluids are liquids or gases and can be studied as real or ideal fluids. An ideal fluid is incompressible and frictionless. A real fluid has viscosity and is compressible. Viscosity is a fluid property of internal friction and may be expressed as dynamic or kinematic values. Typical values of gas and liquid viscosities, dynamic  $\mu$ , and kinematic  $\nu = \mu / \text{density}$ , are as follows in Table 1:

**TABLE 1**

Viscosities

Fluid	Dynamic, $\mu$ lb-sec /ft <sup>2</sup>	Density, $m$ lb-sec <sup>2</sup> / ft <sup>4</sup>	Kinematic, $\nu = \mu / m$ ft <sup>2</sup> /sec
Air	$4 \times 10^{-7}$	.075/32.2	$1.7 \times 10^{-4}$
Water	$2.1 \times 10^{-5}$	62.4/32.2	$1.1 \times 10^{-5}$
Gasoline	$6.2 \times 10^{-6}$	42.4/32.2	$4.7 \times 10^{-6}$
Crude Oil	$1.6 \times 10^{-4}$	53.7/32.2	$9.6 \times 10^{-5}$

The compressibility of a liquid is related to a bulk modulus of elasticity,  $K$ , as follows:

$$K = - (V_o) \frac{dP}{d(V_o)} = m \frac{dP}{dm} \tag{Eq.1}$$

Where  $P$  = pressure, psi,  $V_o$  = volume, ft<sup>3</sup>, and  $m$  = density, lb-sec<sup>2</sup> /ft<sup>4</sup>. Representative values of the bulk modulus  $K$  are shown in Table 2 for several liquids.

**TABLE 2**

Bulk Modulus

Liquid	$K$ , psi
Alcohol	163,000
Glycerine	630,000
Mercury	4,000,000
Oil	225,000
Water, fresh	312,000

Equation 1 may be rearranged to give the change in density with change in pressure as

$$\frac{dm}{m} = \frac{dP}{K} \quad (\text{Eq.2})$$

The compressibility of water is illustrated by considering a pressure change of 100 atmospheres (1470 psi) and finding the percent change in density.

$$\frac{dm}{m} = 100 \frac{1470}{312000} = 0.47 \%$$

This indicates that the compressibility of water is negligible at the pressure changes of much less than 100 atmospheres expected in most cases of fluid flow.

For comparison, the compressibility of gas for isothermal flow is found from Boyle's law,  $(P/m) = \text{constant}$ . Differentiating gives

$$\frac{1}{m} dP - P \frac{dm}{m^2} = 0 \quad \text{or} \quad \frac{dm}{m} = \frac{dP}{P} \quad (\text{Eq.3})$$

For a gas at atmospheric pressure (14.7 psi) and a pressure change of 1/10 atmosphere (1.47 psi), the percent change in density is

$$\frac{dm}{m} = 100 \frac{1.47}{14.7} = 10 \% \quad (\text{isothermal gas})$$

For adiabatic flow, the relation  $(P/m^k) = \text{constant}$  holds and differentiating gives

$$\frac{1}{m^k} dP - kP \frac{dm}{m^{k+1}} = 0 \quad \text{or} \quad \frac{dm}{m} = \frac{dP}{kP} \quad (\text{Eq.4})$$

Where  $k = c_p / c_v$ , ratio of constant pressure specific heat to constant volume specific heat. For air  $k=1.4$ . Other  $k$  values are in Table 3. For air at 14.7 psi and a 1/10 atmosphere pressure change, the percent density change is

$$\frac{dm}{m} = 100 \frac{1.47}{1.4(14.7)} = 7.1 \% \quad (\text{adiabatic gas})$$

Comparing equation 2, 3, and 4 shows that the bulk modulus for a gas undergoing an isothermal process is  $K = P$  and for a gas in an adiabatic process  $K = k P$ .

**TABLE 3**  
Gas Properties 68 Deg F, 1 atm

Gas	Kin Visc, ft <sup>2</sup> /sec	$k=c_p/c_v$	R, ft / deg R	Wt, lb/ft <sup>3</sup>
Air	.00017	1.4	53.3	.075
Propane	.00011	1.15	35.0	.117
Helium	.00115	1.66	386	.01
Hydrogen	.0011	1.41	767	.005
Chlorine	.00015	1.33	21.8	.186
Butane	.00011	1.11	26.5	.155
Ammonia	.000165	1.32	89.5	.045

These results for density change of fluids indicate that gases should be considered not only viscous but compressible and that liquids are viscous but can be considered incompressible for most engineering applications of pipe flow.

Flow types include steady or unsteady, uniform or non-uniform, laminar or turbulent, and isothermal or adiabatic flow. In engineering applications such as at a refinery or chemical processing plant, flow in pipes is maintained for long durations and does not change with time (steady flow). Fluids are pumped through long straight pipes such that the velocity vector does not change in magnitude or direction from place to place along the length of the pipe (uniform flow). Also, it is expected that in many practical applications of pipe flow the flow velocity will be such that the fluid particles will not maintain smooth paths (laminar flow) along the pipe but will break down into irregular paths and cross currents and fluctuations (turbulent flow).

Therefore, to cover pipe flows which are expected to be the most prevalent in engineering applications, this study will be concerned mostly with steady, uniform, turbulent flow of real fluids. Liquid flow and isothermal (constant temperature) and adiabatic (no heat transfer) gas flows, and an unsteady flow case will be considered. The solution to these pipe flow problems begins with the governing equations.

## 2. Governing Equations

The descriptive relations in pipe flow include the continuity equation, the momentum equation, and the energy equation. Additional useful relations are velocity distribution equations, the Reynolds number, the Mach number, the speed of sound, gas laws and the equation of state. Referring to Figure 1, for steady state conditions, these equations are as follows:

Continuity Equation (Conservation of mass)

$$\text{Compressible flow} \quad m_1 A_1 V_1 = m_2 A_2 V_2 \quad (\text{Eq.5})$$

$$\text{Incompressible flow} \quad Q = A_1 V_1 = A_2 V_2 \quad (\text{Eq.6})$$

Where  $m_1, m_2$  = mass density at the pipe entrance and exit respectively

$$= \text{slug/ft}^3 = (\text{lb-sec}^2)/\text{ft}^4$$

$$m_1 = m_2 \text{ for incompressible flow}$$

$$A_1, A_2 = \text{pipe entrance and exit cross section area, ft}^2$$

$$V_1, V_2 = \text{pipe entrance and exit average flow velocity, ft/sec}$$

$$Q = \text{flow rate, ft}^3/\text{sec}$$

Momentum Equation (Conservation of momentum) (vector equations)

$$\text{Compressible flow} \quad F = m_2 A_2 V_2^2 - m_1 A_1 V_1^2 \quad (\text{Eq.7})$$

$$\text{Incompressible flow} \quad F = m Q (V_2 - V_1) \quad (\text{Eq.8})$$

Where  $F$  = sum of forces exerted on the pipe system by the fluid flow, lb

$$m = m_1 = m_2 \text{ for incompressible flow}$$

The velocity  $V$  in equations 7 and 8 is the average velocity over the pipe cross section. As shown in Figure 2, the laminar and turbulent velocities vary over the cross section. To account for this variation from the average, the right side of equations 7 and 8 must be multiplied by a momentum correction factor beta. This factor is approximately as follows:

$$\text{Laminar flow} \quad \text{beta} = 1.33 \quad (\text{Eq.9})$$

$$\text{Turbulent flow} \quad \text{beta} = 1.04 \quad (\text{Eq.10})$$

Energy Equation (Conservation of energy)

Incompressible flow

$$\frac{p_1}{\rho g} + \frac{V_1^2}{2g} + z_1 + H = \frac{p_2}{\rho g} + \frac{V_2^2}{2g} + z_2 + H_L \quad (\text{Eq.11})$$

Compressible isothermal (constant temperature) flow

$$\frac{p_1}{\rho_1 g} \log_e p_1 + \frac{V_1^2}{2g} + z_1 + H = \frac{p_2}{\rho_2 g} \log_e p_2 + \frac{V_2^2}{2g} + z_2 + H_L \quad (\text{Eq.12})$$

Compressible adiabatic (no heat transfer) flow

$$\left(\frac{k}{k-1}\right) \frac{p_1}{\rho_1 g} + \frac{V_1^2}{2g} + z_1 + H = \left(\frac{k}{k-1}\right) \frac{p_2}{\rho_2 g} + \frac{V_2^2}{2g} + z_2 + H_L \quad (\text{Eq.13})$$

where  $p_1, p_2$  = pipe entrance and exit absolute static pressure, lb/ft<sup>2</sup>

$z_1, z_2$  = entrance and exit height from a datum at the pump centerline, above positive, below negative, ft

H = head (designating energy) supplied by the pump or fan, ft

$H_L$  = energy or head loss due to friction, entrance, and fittings, ft

$g = 32.2 \text{ ft/sec}^2$

$\log_e = \ln = \text{natural logarithm}$

and  $m, V, k$  are as previously defined.

The velocity head or kinetic energy term  $V^2/2g$  is based on an average or uniform velocity over the pipe cross section. Both the laminar and turbulent velocities vary from this uniform distribution as shown in Figure 2. To account for this variation, the kinetic energy terms in equations 11, 12, and 13, should be multiplied by a correction factor, alpha, with approximate values as follows:

Laminar flow                      **alpha = 2.0**                      **(Eq.14)**

Turbulent flow                      **alpha = 1.1**                      **(Eq.15)**

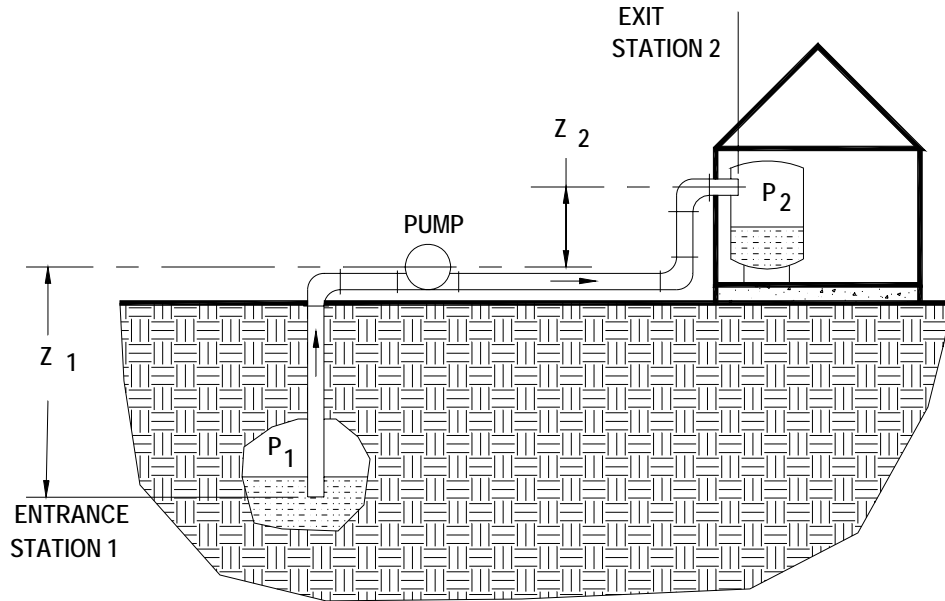

FIGURE 1 PIPE DIAGRAM

Velocity Distributions (see Figure 2)

Laminar flow 
$$V_1(r) = V_{1max} \left(1 - \frac{r^2}{r_o^2}\right) \tag{Eq.16}$$

$$V_{1max} = 2 V_1 = 2 \frac{m_2 A_2 V_2}{m_1 A_1} \tag{Eq.17}$$

Turbulent flow 
$$V_1(r) = V_{1max} \left(1 - \frac{r}{r_o}\right)^{1/7} \tag{Eq.18}$$

$$V_{1max} = \frac{120}{98} V_1 = \left(\frac{120}{98}\right) \frac{m_2 A_2 V_2}{m_1 A_1} \tag{Eq.19}$$

Where  $r_o$  = pipe radius,  $r$  = radial distance from the pipe centerline

$V_1, V_2$  = average velocities

The velocity profiles for Equations 16 and 18 are illustrated in Figure 2.

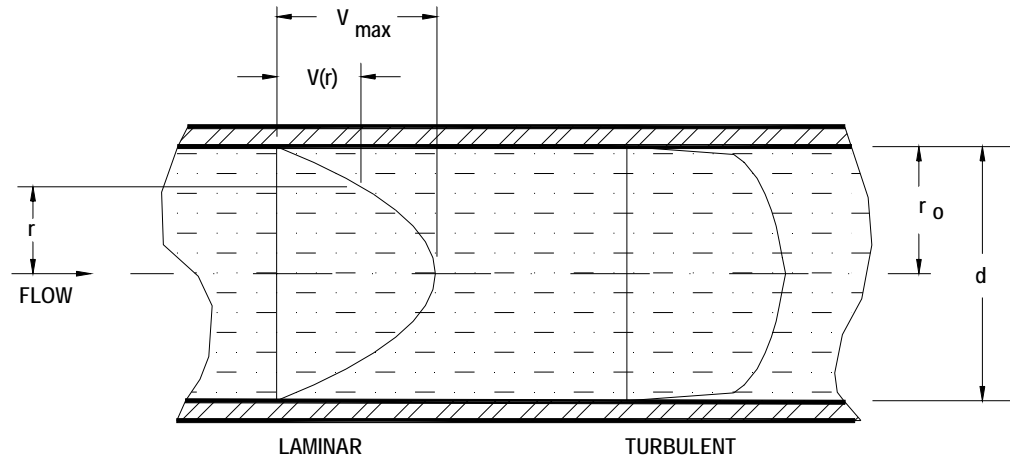

FIGURE 2. PIPE FLOW VELOCITY PROFILES

Reynolds Number,  $Re$

$$Re = \frac{mVd}{u} \quad \text{(Eq.20)}$$

Where

$m$  = fluid mass density slug/ft<sup>3</sup> = lb-sec<sup>2</sup>/ft<sup>4</sup>

$V$  = average velocity, ft/sec

$d$  = pipe diameter, ft

$u$  = fluid dynamic viscosity, lb-sec/ft<sup>2</sup>

The Reynolds Number is a dimensionless number which indicates if the flow is laminar or turbulent. A critical velocity or flow rate can be found from a Reynolds Number of about 2000 at which the flow transitions from the laminar profile to the turbulent profile shown in Figure 2.

$$V_{crit} = 2000 \frac{u}{md} \quad \text{(Eq.21)}$$

$$Q_{crit} = 2000 \frac{uA}{md} \quad \text{(Eq.22)}$$

Speed of sound, a

$$a = \left( \frac{K}{m} \right)^{1/2} \quad \text{(Eq.23)}$$

For water,  $K = 312,000 \text{ lb/in}^2$  (Table 2), and  $m = 62.4 \text{ lb/ft}^3 / 32.2 \text{ ft/sec}^2$  (Table 1), so the speed of sound in water is

$$a = \left( \frac{312000 \text{ lb/in}^2 (144 \text{ in}^2/\text{ft}^2)}{1.94 \text{ lb-sec}^2/\text{ft}^4} \right)^{1/2}$$

$$a = 4812 \text{ ft/sec} \quad \text{(water speed of sound)}$$

Equation 23 is for liquids or gases. But a sound wave passing through gas is essentially an adiabatic (no heat transfer) process so the bulk modulus in equation 23 is  $K = kp$  (see Eq. 2 and 4). From the gas law,  $p = \rho RT$ , so for gases equation 23 becomes

$$a = (k\rho RT)^{1/2} \quad \text{(Eq.24)}$$

where

$R =$  gas constant, ft/deg Rankine (Table 3)

$T =$  temperature, deg Rankine

$=$  deg Fahrenheit + 460

For air,  $k = 1.4$ , and  $R = 53.3 \text{ ft/ deg Rankine}$ , so the speed of sound in air is

$$a = (1.4 (32.2 \text{ ft/sec}^2) (53.3 \text{ ft/deg Rankine}) T)^{1/2}$$

$$a = 49(T)^{1/2} \quad \text{(Eq.25)}$$

For air at 78 deg Fahrenheit, the speed of sound is

$$a = 49 (78 + 460)^{1/2}$$

$$a = 1137 \text{ ft/sec} \quad \text{(air speed of sound)}$$

Mach number, M

$$M = \frac{V}{a} \quad \text{(Eq.26)}$$

The Mach number is an indicator of the importance of compressibility.

The effect of compressibility is seen for the case of gas flow in a pipe where the flow is stopped at a point adiabatically (no heat transfer) such that the velocity  $V_2 = 0$  in the energy equations. For no pump power added  $H = 0$ , no friction losses,  $H_L = 0$ , and a horizontal pipe,  $z_1 = z_2$ . Considering the flow as incompressible, the incompressible energy equation (11) gives

$$p_2 = p_1 + \frac{\rho V_1^2}{2} \quad (\text{Eq.27})$$

The compressible adiabatic energy equation (13) can be put in the form

$$p_2 = p_1 + \frac{\rho V_1^2}{2} \left[ 1 + \frac{1}{4} M_1^2 + \frac{(2-k)}{24} M_1^4 + \dots \right] \quad (\text{Eq.28})$$

Comparing equations 27 and 28 shows the effect of compressibility is to increase the pressure  $p_2$  but for a Mach number less than about  $M = 0.2$ , this increase can be neglected and incompressible equations can be used. For Mach number greater than  $M = 0.2$ , the compressible relations should be used for correct answers. Eq.28 applies only for  $M < 1.0$ .

### Gas Laws

Isothermal (Boyle's) law  $\frac{p}{\rho} = \text{constant} \quad (\text{Eq.29})$

Adiabatic law  $\frac{p}{\rho^k} = \text{constant} \quad (\text{Eq.30})$

Charles' law  $\frac{1}{\rho T} = \text{constant} \quad (\text{Eq.31})$

Equation of state (general gas law)  $p = \rho gRT \quad (\text{Eq.32})$

where  $R$  is the gas constant given in Table 3.  $R$  may also be found from

$$R = 1544/w \quad (\text{Eq.33})$$

Where  $w$  is the molecular weight of the gas. For example the molecular weight of steam,  $H_2O$ , is  $w = 2 + 16 = 18$ , and

$$R_{\text{steam}} = 1544/18 = 85.8 \quad (\text{Eq.34})$$

### 3. Energy Losses

The energy equations 11, 12, and 13, include a loss term  $H_L$ , which is composed of two terms, friction and minor losses.

$$H_L = H_{fric} + H_{minor} \quad (Eq.35)$$

The minor losses are due to fittings such as valves, bends, tees and elbows and are given by

$$H_{minor} = C (V^2 / 2g) \quad (Eq.36)$$

The loss coefficient C is determined by experiment and is shown in Table 4 for several typical pipe fittings.

**TABLE 4**

Pipe Fitting Loss Coefficient

Fitting	C
Return Bend	2.2
90 Elbow	0.7
45 Elbow	0.4
Tee	1.8
Check Valve	2.5
Gate Valve	0.2
Globe Valve	10.0
Entrance	1.0
Exit	1.0

The frictional loss is given by the Darcy-Weisbach equation as follows

$$H_{fric} = f \left( \frac{L}{d} \right) (\alpha) \left( \frac{V^2}{2g} \right) \quad (Eq.37)$$

Where

L = length of the pipe, ft

d = diameter of the pipe, ft

alpha = kinetic energy correction factor (Eq.14, 15)

V = average velocity, ft/sec

f = friction factor

For laminar flow

$$f = 64/Re \quad (Eq.38)$$

For turbulent flow, the friction factor is found from a Moody diagram (in fluid mechanics texts) or from the Colebrook equation given here. To use this equation (or a Moody diagram) the Reynolds Number and the pipe roughness ratio, e/d, must be known. The roughness, e, typical for various pipe materials is given in Table 5.

Colebrook equation 
$$\frac{1}{(f)^{1/2}} = - 2 \log \left[ \frac{e}{3.7d} + \frac{2.51}{\text{Re}(f)^{1/2}} \right] \quad (\text{Eq.39})$$

TABLE 5  
Pipe Roughness

Pipe Material	Roughness e, ft
Concrete	0.004
Welded Steel	0.0002
Riveted Steel	0.007
Cast Iron	0.0008
Copper	0.000005

**4. Incompressible Flow Problems**

The basic pipe flow problems presented here are all solved with the incompressible continuity equation (Eq.6), incompressible energy equation (Eq.11), the Reynolds number (Eq.20), the Darcy-Weisbach equation (Eq.37), and the Colebrook equation (Eq.39).

Problem 1: Crude oil is to be pumped through a mile long 36 inch diameter welded steel pipe at the rate of one million (10<sup>6</sup>) barrels per day. The pipe has a 3 foot elevation increase. An engineer needs to determine the pump horsepower required.

Solution 1:

$$\text{Flow rate } Q = 10^6 \frac{\text{barrels}}{\text{day}} \left( 42 \frac{\text{gallons}}{\text{barrel}} \right) \left( 231 \frac{\text{in}^3}{\text{gal}} \right) \left( \frac{\text{ft}^3}{1728 \text{ in}^3} \right) \left( \frac{\text{day}}{24 \text{ hr}} \right) \left( \frac{\text{hr}}{3600 \text{ sec}} \right)$$

$$Q = 65 \text{ ft}^3 / \text{sec}$$

From continuity,  $Q = AV$  where  $A = 3.14(d^2 / 4) = 3.14(3\text{ft})^2 / 4 = 7 \text{ ft}^2$ .

The average velocity is  $V = Q/A = (65 \text{ ft}^3 / \text{sec}) / 7 \text{ ft}^2 = 9.3 \text{ ft/sec}$ .

From Table 1 crude oil dynamic viscosity is  $\mu = 1.6 \times 10^{-4} \text{ lb-sec/ft}^2$  and the mass density is  $\rho = (53.7 \text{ lb/ft}^3) / 32.2 \text{ ft/sec}^2 = 1.67 \text{ lb-sec}^2 / \text{ft}^4$ .

Solution 1 continued:

From Eq.20 the Reynolds number is

$$Re = \frac{mVd}{u} = (1.67\text{lb-sec}^2/\text{ft}^4)(9.3\text{ft/sec})(3\text{ft})/(0.00016\text{lb-sec}/\text{ft}^2)$$

$$Re = 291,206 \text{ (turbulent flow for } Re > 2000)$$

For this turbulent flow, the energy correction factor, alpha, to be used in the Darcy-Weisbach equation (37) is given by Eq.15, alpha=1.1. Also, the pipe roughness, e, for welded steel pipe is given in Table 5 as e = 0.0002 ft. The relative roughness is e/d = 0.0002/3 = 0.000067

Substitute Re = 291,206 and e/d = 0.000067 in Eq.39. By iteration find a friction factor of f = 0.015. Then the frictional head loss from Eq. 37 is

$$H_{\text{fric}} = 0.015 \left( \frac{5280}{3} \right) (1.1) \left[ \frac{(9.3)^2}{2(32.2)} \right] = 39 \text{ ft}$$

Other losses come from the entrance and exit of the pipe. Table 4 gives the loss coefficient, C, for both entrance and exit as C = 1.0. From Eq.36

$$H_{\text{minor}} = 1.0 \left[ \frac{(9.3)^2}{2(32.2)} \right] + 1.0 \left[ \frac{(9.3)^2}{2(32.2)} \right] = 2.7 \text{ ft}$$

Since the pipe is of constant area, the continuity equation (6) gives constant velocity. Neglecting pressure change due to elevation change, the energy equation (11) gives

$$H = H_{\text{fric}} + H_{\text{minor}} + (z_2 - z_1) = 39 + 2.7 + 3$$

H = 44.7 ft = 44.7 ft-lb/lb meaning that the flow loses 44.7 ft-lb of energy for every lb of fluid flowing and that energy must be input by the pump. The flow rate in pounds is given by

$$Q m g = (65 \text{ ft}^3/\text{sec})(53.7 \text{ lb}/\text{ft}^3) = 3490 \text{ lb}/\text{sec}$$

The power required is given by **P = m g Q H** (Eq.40)

So P = 3490 lb/sec (44.7 ft) = 156,000 ft-lb/sec

The horsepower required is

$$HP = P/550 = 156,000/550 = 284 \text{ hp} \quad \text{Final answer}$$

Problem 2: After the pump in problem 1 was installed, the welded steel pipe had to be replaced with a riveted steel pipe of the same size. The engineer must now determine the effect on the flow rate.

Solution 2: The increased friction in the riveted pipe will decrease the flow rate  $Q$  which is now an unknown so that the velocity  $V$  cannot be found directly from the continuity equation  $Q = AV$ . So the Reynolds number cannot be found for use in the Colebrook equation Eq.39 to find the friction factor  $f$ . But the velocity  $V$  and the friction factor  $f$  can be related using the energy equation Eq.11 and the power equation Eq.40.

$$\text{Eq.40} \quad P = 156000 \text{ ft-lb/sec} = mgQH = AV(53.7 \text{ lb/ft}^3)H$$

$$\text{Or} \quad H = \frac{156000}{7(53.7)V} = \frac{415}{V} \quad \text{where } A=7 \text{ ft}^2 \text{ is used}$$

$$\text{Eq.11} \quad H = f\left(\frac{L}{d}\right)\left(\frac{V^2}{2g}\right) + 2C\left(\frac{V^2}{2g}\right) + (z_2 - z_1)$$

$$\text{Or} \quad H = f\left(\frac{5280}{3}\right)(1.1)\left(\frac{V^2}{64.4}\right) + 2(1)\left(\frac{V^2}{64.4}\right) + 3$$

$$H = [30f + 0.03] V^2 + 3$$

Eliminating  $H$  using the second and last equation above gives

$$415 = [30f + 0.03] V^3 + 3V$$

This last equation must now be solved by trial and error for  $f$  and  $V$  as follows: The roughness of a riveted steel pipe from Table 5 is  $e=.007$  ft. The relative roughness is  $e/d = .007/3 = .0023$ . Since the increased pipe roughness is expected to reduce the velocity and Reynolds number from those of problem 1, estimate a Reynolds number at 270,000 and enter this and  $e/d=.0023$  in Eq.39. Then by trial and error find a friction factor of approximately  $f=.025$ . Using this in the above equation gives

$$415 = [30(.025) + 0.03]V^3 + 3V$$

$$415 = .78V^3 + 3V$$

By trial and error the velocity that satisfies the relation is  $V=7.95$  ft/sec.

$$415 = .78(7.95)^3 + 3(7.95)$$

$$415 = .78(502) + 24 = 391 + 24 = 416 \quad \text{ok}$$

With this first estimate of flow velocity, a Reynolds number can be found.

Solution 2 continued:

$$\text{Eq.20} \quad \text{Re} = \frac{mVd}{u} = \frac{(53.7/32.2)(7.95)(3)}{0.00016} = 248,591$$

Entering equation 39 at this Reynolds number and the roughness  $e/d=.0023$  obtain a second estimate of friction factor of about  $f=.0255$ . This is close enough to require no further iterations. If the difference in estimated friction factor had been larger, a second velocity would have been obtained using the above procedure and the process repeated until  $f$  was within the desired accuracy. With the velocity  $V=7.95$  ft/sec determined, the flow rate  $Q$  can be found.

$$\text{Eq.6} \quad Q = AV = 7 \text{ ft}^2 (7.95 \text{ ft/sec}) = 55.65 \text{ ft}^3 / \text{sec}$$

Converting this to barrels of crude oil per day gives

$$Q = 55.65 \frac{\text{ft}^3}{\text{sec}} \left( \frac{3600 \text{ sec}}{\text{hr}} \right) \left( \frac{24 \text{ hr}}{\text{day}} \right) \left( \frac{1728 \text{ in}^3}{\text{ft}^3} \right) \left( \frac{\text{gallon}}{231 \text{ in}^3} \right) \left( \frac{\text{barrels}}{42 \text{ gallons}} \right)$$

$$Q = 856,370 \frac{\text{barrels}}{\text{day}}$$

The frictional and minor losses for this flow are as follows;

$$\text{Eq.37} \quad H_{\text{fric}} = .025 \left( \frac{5280}{3} \right) (1.1) \left[ \frac{(7.95)^2}{2(32.2)} \right] = 47.5 \text{ ft}$$

$$\text{Eq.36} \quad H_{\text{minor}} = 2(1.0) \left[ \frac{(7.95)^2}{2(32.2)} \right] = 1.96 \text{ ft} \quad (\text{for entrance plus exit})$$

Check of energy requirement for agreement with problem 1:

$$\text{Eq.11} \quad H = H_{\text{fric}} + H_{\text{minor}} + (z_2 - z_1)$$

$$H = 47.5 + 1.96 + 3 = 52.46 \text{ ft}$$

$$\text{Eq.40} \quad P = mg Q H = 55.65 \frac{\text{ft}^3}{\text{sec}} \left( 53.7 \frac{\text{lb}}{\text{ft}^3} \right) (52.46 \text{ ft}) = 156,771 \frac{\text{ft-lb}}{\text{sec}} \quad \text{ok}$$

These results show, for the same pumping power, there is a 15% loss in output capacity  $Q$  due to the increased frictional losses of the riveted steel pipe over the welded steel pipe.

Problem 3: An engineer is assigned the design task of determining the pipe diameter required for pumping one million barrels per day of crude oil through one mile of welded steel pipe with a 3 foot elevation increase using an available 41 horsepower pump.

Solution 3: Since the diameter of the pipe is unknown, the flow velocity  $V$  cannot be determined from the continuity equation  $Q=AV$ , and the Reynolds number  $Re$  and friction factor  $f$  cannot be found directly. These three unknowns can be related using the governing equations, continuity Eq.6, energy Eq.11, Reynolds number Eq.20, loss equations Eq.36 and 37, and the power relation Eq.40 as follows:

$$Q = 1,000,000 \frac{\text{barrels}}{\text{day}} \left(42 \frac{\text{gallons}}{\text{barrel}}\right) \left(231 \frac{\text{in}^3}{\text{gal}}\right) \left(\frac{\text{ft}^3}{1728 \text{ in}^3}\right) \left(\frac{\text{day}}{24 \text{ hr}}\right) \left(\frac{\text{hr}}{3600 \text{ sec}}\right)$$

$$Q = 65 \text{ ft}^3 / \text{sec}$$

From Eq.6 
$$V = Q/A = \frac{4(65)}{3.14(d^2)} = \frac{82.8}{d^2}$$

For a constant diameter pipe,  $A_1 = A_2$ , and the continuity equation gives  $V_1 = V_2$ . Neglecting pressure change across the pipe and substituting equations 36 and 37 in 11 gives

$$H = f\left(\frac{L}{d}\right)(1.1)\left(\frac{V^2}{2g}\right) + 2C\left(\frac{V^2}{2g}\right) + (z_2 - z_1)$$

Substituting known values gives

$$H = f\left(\frac{5280}{d}\right)(1.1)\left(\frac{V^2}{64.4}\right) + 2(1.0)\left(\frac{V^2}{64.4}\right) + 3$$

$$H = 90f \frac{V^2}{d} + .031V^2 + 3$$

Using the result of Eq.6 above to eliminate  $V$  gives

$$H = 90f \frac{(82.8)^2}{d^5} + .031 \frac{(82.8)^2}{d^4} + 3 = 617025 \frac{f}{d^5} + \frac{213}{d^4} + 3$$

From Eq.40 
$$P = 41 \text{ hp}(550 \text{ ft-lb/sec})/\text{hp} = 22550 \text{ ft-lb/sec}$$
  

$$P = mg QH$$

Solution 3 continued:

$$\text{Or } H = 22550 / (\text{mg } Q) = \frac{22550 \text{ ft-lb/sec}}{(53.7 \text{ lb/ft}^3)(65 \text{ ft}^3/\text{sec})} = 6.46 \text{ ft}$$

Eliminating H gives

$$6.46 = 617025 \frac{f}{d^5} + \frac{213}{d^4} + 3$$

$$\text{Or } 3.46 = 617025 \frac{f}{d^5} + \frac{213}{d^4}$$

This last equation must now be solved by trial and error for f and d. First guess a value for the friction factor such as  $f = .02$  to give

$$3.46 = 617025 \frac{(.02)}{d^5} + \frac{213}{d^4} = \frac{12341}{d^5} + \frac{213}{d^4}$$

By trial and error the diameter  $d = 5.22$  is found to approximately satisfies this equation. Use this diameter to find a relative roughness and Reynolds number.

$$e/d = .0002/5.22 = .000038$$

$$\text{Re} = \frac{mVd}{u} = \frac{m(82.8)}{ud} \text{ by using Eq.6 results for } V \text{ above}$$

$$\text{Or } \text{Re} = \frac{(53.7/32.2)(82.8)}{(.00016)(5.22)} = 165,333$$

Now from equation 39 obtain a new friction factor  $f = .016$  which when used in the above equations gives a new diameter d. This process can be repeated to obtain a final diameter  $d = 5$  feet which is the pipe diameter required to obtain a flow rate of one million barrels per day of crude oil using 41 hp.

$$\text{Also the velocity can now be found as } V = \frac{82.8}{d^2} = \frac{82.8}{(5)^2} = 3.3 \text{ ft/sec}$$

Problems 1, 2, and 3 illustrate basic procedures in pipe flow calculations used in solving problems where pump size or energy losses are unknown or where flow rate or pipe diameter are to be found.

Problem 4: Figure 1 represents a domestic water shallow well 20 feet deep. The pipe is cast iron 1.38 inch inside diameter. From the pump to the house the pipe is 100 feet horizontal and 30 feet vertical. The pressure tank in the house is 40 gallons. The pump is to turn on at 30 psi gage when the tank is

down 10 gallons and is to have a shutoff pressure of 56 psi gage. The tank is to refill in 1.5 minutes. An engineer must determine the pump size needed.

Solution 4: The flow rate required is  $Q = 10 \text{ gal}/1.5 \text{ min} = 6.7 \text{ gal}/\text{min}$ .

$$\text{Or } Q = 6.7 \frac{\text{gal}}{\text{min}} \left( \frac{231 \text{ in}^3}{\text{gal}} \right) \left( \frac{\text{ft}^3}{1728 \text{ in}^3} \right) \left( \frac{\text{min}}{60 \text{ sec}} \right) = .015 \text{ ft}^3 / \text{sec}$$

From continuity (Eq.6) the velocity in the pipe section is

$$V = Q/A = (.015 \frac{\text{ft}^3}{\text{sec}}) / \left[ \frac{3.14(1.38/12)^2}{4} \text{ft}^2 \right]$$

$$V = 1.44 \text{ ft}/\text{sec}$$

Using the properties of water in Table 1, the Reynolds numbers (Eq.20) for this velocity is

$$\text{Re} = \frac{mVd}{u} = \frac{[(62.4/32.2) \text{lb-sec}^2/\text{ft}^4](1.44 \text{ ft}/\text{sec})[(1.38/12) \text{ft}]}{.000021 \text{ lb-sec}/\text{ft}^2}$$

$$\text{Re} = 15,282 \quad (>2000 \text{ therefore turbulent flow})$$

Using the pipe roughness in Table 5, the relative roughness of the cast iron pipe section is

$$\left( \frac{e}{d} \right) = \frac{.0008}{(1.38/12)} = .00695$$

Since the pipe flow is turbulent, the Colebrook equation (Eq.39) must be used to find the friction factor  $f$ . Substituting the  $\text{Re}$  and  $e/d$  values in the equation, by trial and error the following factor can be found:

$$f = 0.038$$

From Eq.37 and Eq.15 the frictional loss in the pipe section is

$$H_{\text{fric}} = f \left( \frac{L}{d} \right) (\alpha) \left( \frac{V^2}{2g} \right) = .038 \left[ \frac{150}{(1.38/12)} \right] (1.1) \left[ \frac{(1.44)^2}{64.4} \right]$$

$$H_{\text{fric}} = 1.76 \text{ ft-lb}/\text{lb}$$

The minor loss in the pipe section can be found from Eq.36 and the data in Table 4 as follows:

Solution 4 continued:

$$H_{\text{minor}} = (C_{\text{entrance}} + 3C_{\text{elbow}} + C_{\text{exit}}) \left( \frac{V^2}{2g} \right) = [1.0 + 3(0.7) + 1.0] \left[ \frac{(1.44)^2}{64.4} \right]$$

$$H_{\text{minor}} = 0.13 \text{ ft-lb/lb}$$

From Eq.35 the total losses are

$$H_L = 1.76 + 0.13 = 1.89 \text{ ft-lb/lb}$$

From Eq.11 the pump work that must be supplied is (neglect alpha)

$$H = \left( \frac{p_2 - p_1}{mg} \right) + \left( \frac{V_2^2 - V_1^2}{2g} \right) + (z_2 - z_1) + H_L$$

Where  $p_2 = (56 \text{ psi} + 14.7 \text{ psi})(144 \text{ in}^2 / \text{ft}^2) = 10181 \text{ lb/ft}^2$

$$p_1 = 14.7(144) = 2117 \text{ lb/ft}^2 \text{ (atmospheric at well surface)}$$

$$V_2 = V = 1.44 \text{ ft/sec at the pipe exit}$$

$$V_1 = 0 \text{ at the well water surface}$$

$$z_2 = 20 \text{ ft}$$

$$z_1 = -30 \text{ ft (minus because below pump centerline)}$$

$$mg = 62.4 \text{ lb/ft}^3$$

Then  $H = \left[ \frac{(10181 - 2117)}{62.4} \right] + \left[ \frac{(1.44)^2}{64.4} \right] + (20 + 30) + 1.89$

$$H = 181 \text{ ft-lb/lb}$$

The power from Eq.40 is

$$P = mg Q H = (.015 \text{ ft}^3 / \text{sec}) (62.4 \text{ lb/ft}^3) (181 \text{ ft-lb/lb}) = 169 \text{ ft-lb/sec}$$

Finally, assuming a 60% overall efficiency of motor and pump, the horsepower required is

$$HP = \frac{169 \text{ ft-lb/sec}}{(.6)(550 \text{ ft-lb/sec})} = 0.5 \text{ hp}$$

The pressure at the pump inlet can be checked by applying the energy Eq.11 between the surface of the water outside the suction pipe and the entrance to the pump. With no pump work and neglecting friction loss, Eq.11 becomes

Solution 4 continued:

$$\frac{p_1}{\rho g} + \frac{V_1^2}{2g} + z_1 = \frac{p_{ent}}{\rho g} + \frac{V_{ent}^2}{2g} + z_{ent}$$

where  $p_1 = 14.7$  psi ,  $V_1 = 0$ ,  $z_1 = 0$ ,  $V_{ent} = 1.44$  ft/sec,  $z_{ent} = 20$  ft, and  $p_{ent}$  , the pressure at the pump entrance, is to be found.

$$14.7 \text{ psi} + 0 + 0 = p_{ent} + \frac{(1.44 \text{ ft/sec})^2(62.4 \text{ lb/ft}^3)}{(64.4 \text{ ft/sec}^2)(144 \text{ in}^2/\text{ft}^2)} + \frac{(20 \text{ ft})(62.4 \text{ lb/ft}^3)}{144 \text{ in}^2/\text{ft}^2}$$

from which  $p_{ent} = 6$  psi which is well above the vapor pressure of water.

If the well had been 32 feet deep, the pump entrance pressure would have been  $p_{ent} = 0.8$  psi. Since this is approximately the vapor pressure of water, cavitation would probably occur and cause damage to the pump components.

Shallow well pumps are usually limited to a suction side lift (or well depth) of about 25 feet. For wells deeper than this a submersible pump can be used at the bottom of the well.

Problem 5: The well in problem 4 is converted to a deep well 560 ft deep. A submersible pump is placed at the bottom of the well such that  $z_1 = 0$  and the elevation  $z_2 = 560 + 30 = 590$  ft. With ever thing else the same, what is the new pump size required? (Neglect additional friction loss)

Solution 5: Substituting the calculations from problem 4 and the new well depth into the energy equation Eq.11 gives

$$H = \left[ \frac{(10181-2117)}{62.4} \right] + \left[ \frac{(1.44)^2}{64.4} \right] + 590 + 1.89$$

$$H = 721 \text{ ft-lb/lb}$$

From Eq. 40 the power required is

$$P = \rho g Q H = (.015 \text{ ft}^3/\text{sec}) (62.4 \text{ lb/ft}^3)(721 \text{ ft-lb/lb})$$

$$P = 675 \text{ ft-lb/sec}$$

At 80% efficiency the horsepower required is

$$HP = 675/[(.8)(550)] = 1.5 \text{ hp}$$

Problem 6: At the outlet of the 3 foot diameter pipeline in problem 1 the flow goes through a 30 degree elbow in a horizontal plane. An engineer needs to determine the thrust forces on the elbow in order to design an adequate anchor. Assume the pressure in the pipe is atmospheric.

Solution 6: Define an x-y coordinate system with the origin at the elbow entry, the +x in the direction of the flow, and +y in the direction the flow turns. Summing the forces on the pipe, the thrust on the elbow is given by the momentum equation Eq.8. The x and y components of force pushing on the elbow are from Eq.8 with correction from Eq.10

$$p_{1x} A - p_{2x} A + F_x = m Q (V_{2x} - V_{1x})(\beta)$$

$$p_{1y} A - p_{2y} A + F_y = m Q (V_{2y} - V_{1y})(\beta)$$

From problem 1 the velocity  $V = 9.3$  ft/sec, flow rate  $Q = 65$  ft<sup>3</sup>/sec, area  $A = 7$  ft<sup>2</sup>, Reynolds number  $Re = 209,206$  and the mass density is  $m = 53.7/32.2 = 1.67$  lb-sec<sup>2</sup>/ft<sup>4</sup>. Then the velocities and pressure forces are

$$V_{1x} = V = 9.3, \quad V_{2x} = V \text{ Cosine } 30 = 9.3 \text{ Cosine } 30 = 9.3 (0.866)$$

$$V_{1y} = 0, \quad V_{2y} = V \text{ Sine } 30 = 9.3 \text{ Sine } 30 = 9.3 (0.5)$$

$$p_{1x} A = 14.7(7)(144) = 14,818 \text{ lb}, \quad p_{2x} A = 14,818 \text{ Cosine } 30$$

$$p_{1y} A = 0, \quad p_{2y} A = 14,818 \text{ Sine } 30$$

So the force components are

$$F_x = 14,818(.866 - 1) + 1.67 (65)(9.3)(.866 - 1)(1.04) = -2126 \text{ lb}$$

$$F_y = 14,818(0.5) + 1.67 (65)(9.3)(0.5)(1.04) = 7934 \text{ lb}$$

The total resultant thrust force on the elbow is then

$$F = [2126^2 + 7934^2]^{1/2} = 8214 \text{ lb}$$

## 5. Compressible Flow Problems

For these problems, the equations used are the compressible continuity Eq.5, compressible energy Eq.12 or 13, speed of sound Eq.24, the Mach number Eq.26, and the gas laws Eq.29, 30, 31 and 32, and Reynolds number Eq.20.

Problem 7: Ammonia at 68 degrees Fahrenheit is to be pumped through a 2 inch inside diameter insulated pipe to a tank at the rate of 20 ft<sup>3</sup> /sec. The tank is maintained at a gage pressure of 5.3 psi and temperature of 68 degrees Fahrenheit. An engineer needs to find the static pressure required at the pump outlet.

Solution 7: For the 68 degree temperature, and k and R from Table 3, the speed of sound in the ammonia is given by Eq.24 as

$$a = [k g R T]^{1/2} = [1.32(32.2)(89.5)(68 + 460)]^{1/2} = 1417 \text{ ft/sec}$$

From the flow rate of 20 ft<sup>3</sup> /sec, the average velocity in the pipe is

$$V = Q/A = \frac{20}{(3.14)(2/12)^2/4} = 917 \text{ ft/sec}$$

and  $Re = \rho V d / \mu = V d / \nu = 917(2/12) / (.000165) = 926,262$  (turbulent)

So the Mach number is  $M = V/a = 917/1417 = .65$ . Since  $M > .2$ , the energy equation for compressibility will be used. Because the pipe is insulated for no heat transfer, the adiabatic relation Eq.13 applies. Neglecting frictional losses and elevation changes, and writing the energy equation between the pump outlet (1) and the tank (2) where the velocity  $V_2 = 0$  gives

$$\left[ \frac{k}{(k-1)} \right] \left[ \frac{p_1}{m_1 g} \right] + \frac{V_1^2}{2g} \quad (1.1) = \left[ \frac{k}{(k-1)} \right] \left[ \frac{p_2}{m_2 g} \right] \quad \text{using Eq.15}$$

where there are three unknowns,  $p_1$ ,  $m_1$ , and  $m_2$ . Since the pressure and temperature are known in the tank the density,  $m_2$ , can be found from the equation of state Eq.32.

$$p_2 = m_2 g R T_2$$

$$\text{or } m_2 = \frac{p_2}{g R T_2} = \frac{(5.3+14.7)(144) \text{ lb/ft}^2}{(32.2 \text{ ft/sec}^2)(89.5 \text{ ft/R})(68+460) \text{ R}} = .00189 \text{ slug/ft}^3$$

Note that absolute pressures must be used in compressible equations.

Solution 7 continued: This leaves one energy equation and two unknowns. The second equation needed is the adiabatic gas law Eq.30.

$$\frac{p_1}{m_1^k} = \frac{p_2}{m_2^k} \quad \text{or} \quad m_1 = m_2 \left( \frac{p_1}{p_2} \right)^{1/k}$$

Using this to eliminate  $m_1$  from the energy equation and rearranging to solve for the pump outlet static pressure gives

$$p_1^{(k-1)/k} = p_2^{(k-1)/k} - \left[ \frac{(k-1)}{k} \right] \left[ \frac{m_2}{p_2^{1/k}} \right] \left[ \frac{V_1^2}{2} \right] \quad (1.1)$$

The values on the right hand side of the equation are  $m_2 = .00189$  slug/ft,  $p_2 = 5.3+14.7 = 20$  psia (144) = 2880 lb/ft<sup>2</sup>,  $k=1.32$  (for ammonia from Table 3), and  $V_1 = 917$  ft/sec. Substituting these and solving gives

$$p_1^{.24} = (2880)^{.24} - (.24) \left[ \frac{.00189}{(2880)^{.758}} \right] \left[ \frac{(917)^2}{2} \right] \quad (1.1)$$

$$p_1 = 14.5 \text{ psia} \quad \text{static pressure at pump outlet}$$

Then the density in the pipe from Eq.30 is  $m_1 = .00189 \left[ \frac{14.5}{20} \right]^{1/1.32}$  or

$$m_1 = .00148 \text{ slug/ft}^3$$

For comparison, if this problem is worked using the incompressible equation assuming density constant at the tank value  $m = .00189$  slug/ft<sup>3</sup>, then Eq.11 gives

$$p_1 = p_2 - \frac{mV^2}{2} \quad (1.1) = 20(144) - \frac{.00189(917)^2}{2} \quad (1.1) = 2006 \text{ lb/ft}^2 = 13.9 \text{ psia}$$

So while the density changes  $(.00189 - .00148)/.00189 = 22\%$  the increase in static pressure is only  $(14.5-13.9)/14.5 = 4\%$  when accounting for the gas compressibility. However this could result in selection of an undersize pump.

Problem 8: Propane flows isothermally in a pipe with a 2 inch inside diameter at a velocity  $V_1 = 650$  ft/sec, an absolute pressure  $p_1 = 35$  psia, and temperature  $T_1 = 68$  degree Fahrenheit. The flow enters a conical diverging section (1) with an outlet (2) 4 inches in diameter. The engineer designing the section and joint has to determine the thrust exerted by the flow on the diverging section. ( $Re = 984,848$  at section 1)

Solution 8: The force on the section is from the differences in static pressures and area of the two pipe diameters and the change in momentum of the flow given by Eq.7 with momentum correction from Eq.10

$$F = [ p_2 A_2 - p_1 A_1 ] + [ m_2 A_2 V_2^2 - m_1 A_1 V_1^2 ] \text{ (beta)}$$

The density  $m_1$  can be found from the equation of state Eq.32 or

$$m_1 = \frac{p_1}{gRT_1} = \frac{35(144)\text{lb/ft}^2}{(32.2 \text{ ft/sec}^2)(35 \text{ ft/R})(68+460)\text{R}} = .00847 \text{ lb-sec}^2 / \text{ft}^4$$

where the gas constant  $R=35$  is from Table 3. Now the pressure  $p_2$ , velocity  $V_2$  and density  $m_2$  must be found. Starting with Eq.12 the compressible isothermal energy equation applied at sections 1 and 2 across the diverging section where there is no pump and no elevation change, neglecting friction loss, gives, with correction from Eq.15

$$\frac{p_1}{m_1 g} \log_e p_1 + \frac{V_1^2}{2g} \text{ (alpha)} = \frac{p_2}{m_2 g} \log_e p_2 + \frac{V_2^2}{2g} \text{ (alpha)}$$

Since there are 3 unknowns in this equation, two additional equations are needed. These are the isothermal gas relation Eq.29 and the compressible continuity equation Eq.5.

$$\text{Eq.29} \quad \frac{p_1}{m_1} = \frac{p_2}{m_2} \quad \text{or} \quad \frac{m_1}{m_2} = \frac{p_1}{p_2}$$

$$\text{Eq.5} \quad V_2 = \frac{m_1 A_1}{m_2 A_2} V_1 = \frac{p_1 A_1}{p_2 A_2} V_1$$

Substituting these relation into the energy equation to eliminate  $m_2$  and  $V_2$  and rearranging gives

$$\frac{p_1}{m_1 g} \log_e \frac{p_2}{p_1} = \frac{V_1^2}{2g} \left[ 1 - \left( \frac{p_1}{p_2} \right)^2 \left( \frac{A_1}{A_2} \right)^2 \right] \text{ (alpha)}$$

Solution 8 continued: The last equation has only one unknown,  $p_2$ , and can be solved by successive trial guesses. An initial guess for  $p_2$  could be 48 psia. Second and third trials could be higher and lower to find which causes the equation to converge. In this manner it is found the pressure  $p_2$  is

$$p_2 = 51 \text{ psia}$$

Then using continuity Eq.5 above, the velocity  $V_2$  is

$$V_2 = \left(\frac{35}{51}\right) \left(\frac{2^2}{4^2}\right) (650) = 112 \text{ ft/sec}$$

From the gas law the density  $m_2$  is

$$m_2 = .00847 \left(\frac{51}{35}\right) = .0123 \text{ lb-sec}^2/\text{ft}^4$$

With all flow properties now determined, the force on the divergent section of pipe can now be found.

$$\begin{aligned} F &= (51) \left(\frac{3.14}{4}\right) (4)^2 - (35) \left(\frac{3.14}{4}\right) (2)^2 \\ &\quad + .0123 \left(\frac{3.14}{4}\right) \left(\frac{4}{12}\right)^2 (112)^2 (1.04) - .00847 \left(\frac{3.14}{4}\right) \left(\frac{2}{12}\right)^2 (650)^2 (1.04) \\ F &= 641 - 110 + 14.0 - 81 = 464 \text{ lb} \end{aligned}$$

## 6. Unsteady Flow

Problem 9: A mile long section of crude oil pipe line 3 feet in diameter is shut down for repairs by closing a valve at the outlet and turning off the pump at the inlet so the pipe is filled with liquid at zero velocity. After completion of repairs, the pump is started and the valve opened. The pump supplies a constant head equivalent of a 44.7 ft column of crude oil. An engineer must determine the time for the fluid to be accelerated to the final velocity and return the pipe flow to full capacity.

Solution 9: In this case the final velocity is known from problem 1 as 9.3 ft/sec. If this velocity is not known, an estimate can be made from Eq.11 the energy equation. The final velocity will be that velocity at which the friction losses from the Darcy-Weisbach equation Eq.37, are equal to the pump head supplied, neglecting other minor losses. From the energy equation this is

$$H = f \left(\frac{L}{d}\right) (\text{alpha}) \left(\frac{V_f^2}{2g}\right)$$

Solution 9 continued: Estimating an  $f = .018$  gives

$$V_f = \left[ \frac{2gdH}{fL(\alpha)} \right]^{1/2} = \left[ \frac{2(32.2)(3)(44.7)}{.018(5280)(1.1)} \right]^{1/2}$$

$$V_f = 9.1 \text{ ft/sec}$$

At velocity less than this final velocity, the frictional loss will be less than the pump head so that there is unbalanced head given by

$$H - f \left( \frac{L}{d} \right) (\alpha) \left( \frac{V^2}{2g} \right) > 0$$

Or 
$$f \left( \frac{L}{d} \right) (\alpha) \left( \frac{1}{2g} \right) [ V_f^2 - V^2 ] > 0$$

The time to establish the final velocity can be determined from Newton's equation of motion, force  $F = \text{mass} \times \text{acceleration}$ . The force  $F$  is given by the unbalanced head above times the weight of a column of fluid of cross section area  $A$ . This force accelerates the mass of fluid in the pipe of section  $A$  and length  $L$  or

$$mgAf \left( \frac{L}{d} \right) (\alpha) \left( \frac{1}{2g} \right) [ V_f^2 - V^2 ] = mA L \left( \frac{dV}{dt} \right)$$

Rearranging to separate the variables of this differential equation gives

$$dt = \frac{2d}{f(\alpha)} \left[ \frac{dV}{(V_f^2 - V^2)} \right]$$

From the first equation  $\frac{2d}{f(\alpha)} = \frac{LV_f^2}{gH}$  so the above equation becomes

$$dt = \frac{LV_f^2}{gH} \left[ \frac{dV}{(V_f^2 - V^2)} \right] = \frac{LV_f}{2gH} \left[ \frac{2V_f dV}{(V_f^2 - V^2)} \right]$$

Integrating both sides gives the final expression

$$t = \frac{LV_f}{2gH} \ln \left[ \frac{(V_f + V)}{(V_f - V)} \right]$$

From this equation it can be seen that it would take an infinite time for  $V$  to become  $V_f$ . For practical applications,  $V = .95 V_f$  can be considered the final velocity. The corresponding time is

$$t = \frac{5280(9.1)}{2(32.2)(44.7)} \ln \left[ \frac{1.95}{.05} \right] = 61 \text{ seconds}$$

This is the time required for the pipe flow to reach steady state conditions.

## Course Summary

This course has presented basic methods of solving problems of fluid flow in pipes. The compressibility and viscosity properties of liquids and gasses were reviewed. For both compressible and incompressible fluids, and for isothermal and adiabatic gases, the governing equations of continuity, momentum, and energy were presented. Gas laws and relations for acoustic velocity, Mach number, and Reynolds number were also given. Equations for energy loss in pipe flow due to viscous friction and pipe fittings were defined. Relations for friction factors for both laminar and turbulent flow were included. Velocity profiles were shown for laminar and turbulent flow. Example problems were presented for incompressible and compressible and adiabatic and isothermal pipe flow. Different solution methods were shown for finding various flow quantities for viscous turbulent steady uniform flow. Examples of thrust forces on pipe fittings using momentum equations were included. Finally, a problem of unsteady flow was presented.

## References

1. Fluid Mechanics, Victor L Streeter, McGraw-Hill, 1958
2. Fluid Mechanics & Hydraulics, Ranald V. Giles, McGraw-Hill, 1962
3. Mechanical Engineering, Gerald Coren, Arco Publishing, 1965
4. Standard Handbook for Mechanical Engineers, Theodore Baumeister and Lionel S. Marks, McGraw-Hill, 1967