

Avoiding Falsework Failure

Course Content

Falsework failure can be a catastrophic collapse; destroying property and killing people. A prime example is the walkway collapse in NYC that was caused by a seeming insignificant detail change from the design. Fortunately, such disasters are rare. False work failure is also excessive settlement, sagging and misalignment, which can cause the bridge to be rebuilt or extensively rehabilitated.

These failures can occur in any element of the falsework system. A typical box girder bridge is selected to demonstrate the various points of consideration because such a falsework system can generate all the problems and considerations encountered in any falsework design.

The usual sequence of post-tensioned box girder concrete bridges is:

- 1- Set and grade falsework
- 2- Set rebar and stem forms
- 3- Pour bottom deck and stem concrete
- 4- Strip inside stem forms and reuse to form top deck soffit
- 5- Rebar and pour top deck concrete
- 6- Cure concrete to the desired compressive strength
- 7- Post-tension bridge
- 8- Strip false work

The above sequence is important to the design of the various elements of the falsework. From the top down:

- 1- The plywood bottom deck soffit carries only the weight of the deck, except under the stems, and blocks.
- 2- The bottom deck soffit joist carries only the weight of the deck, except at the stems, and blocks.
- 3- The longitudinal beams carries the bottom deck and stems and blocks below the top deck. This due to the fact that the set concrete stem is usually much stiffer than the falsework beams.
- 4- The caps and posts carry their proportion of the full bridge weight, forms, falsework and live load.

Please note that closely spaced falsework posts are shown at the hinge. The reason for this is the bridge superstructure box will camber upward when post-tensioned. The mid-span falsework will be unloaded and the bridge weight transferred to the pier, abutment and hinge support. This causes the hinge support falsework to support 30 to 50% of the total hinge span weight; depending on a number of bridge configuration elements.

A common freeway type bridge is the post-tensioned concrete box girder as sketched below:

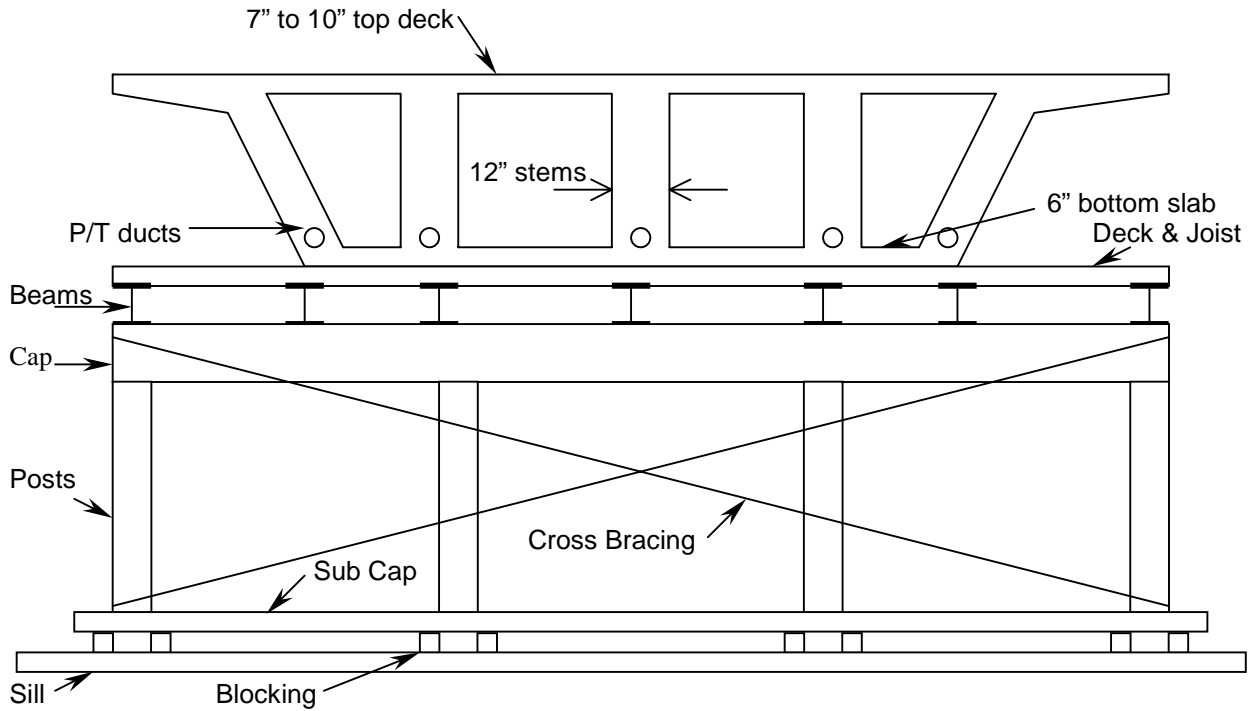

TYPICAL BRIDGE SECTION

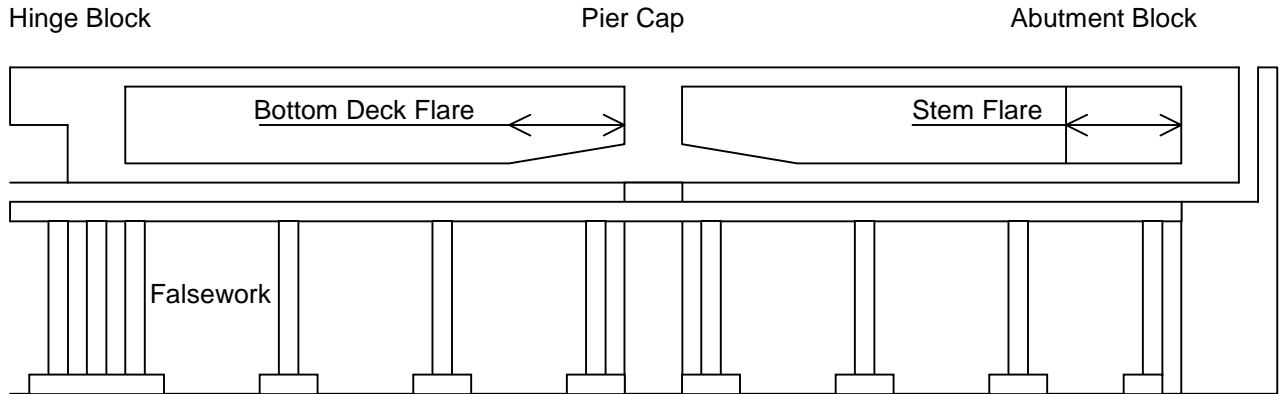

TYPICAL LONGITUDNAL SECTION

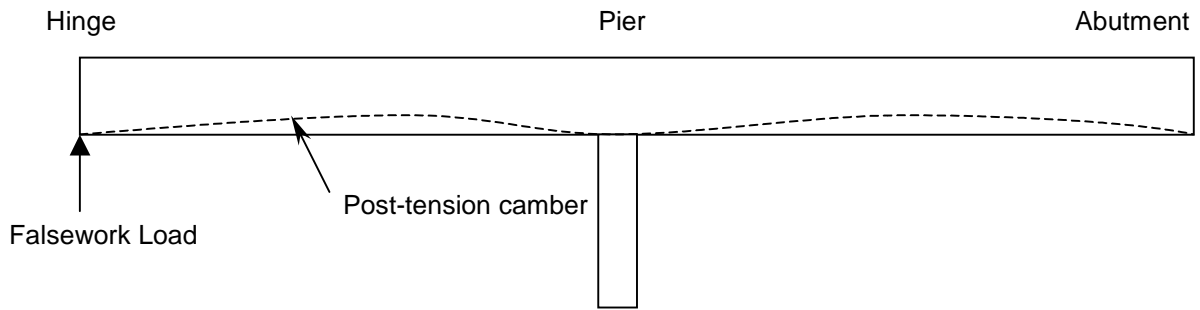

CAMBER DIAGRAM

This very large load concentrated on the hinge falsework means that crushing of the soffit joist timber must be considered. Web crippling of the beams and caps must be analyzed. This falsework must be left in place until the load can be transferred to the next segment of the bridge. The potential of long term loading and severe weather conditions causes a careful consideration of the bearing soil condition and possible long term settlement.

An initial consideration is wind. The cross bracing must be designed for lateral stability during the initial concrete pours and especially when the outside stem forms are in place and there is no significant weight. Tall narrow falsework can easily be blown over by a strong wind. In some cases, the false work must be anchored to prevent overturning. If that portion of the bridge under construction is mounted on sliding bearings that provide no lateral resistance, then the cross bracing must provide lateral stability for the entire bridge weight plus wind loading.

Earthquake forces, rare floods, and unusual winds are usually not applied to the falsework design due to the low probability of a significant occurrence while under load. Many agencies have an "Act of God" clause that protects the contractor for unusual events. The "Act of God" criteria are usually defined by the specifications. Often these clauses cover only the permanent structure and not the contractor's materials, equipment and personnel. In the absence of such clauses the designer must select reasonable criteria for the falsework design.

One very good source is the State of California Falsework Manual.

The bottom deck soffit is usually 5/8" or 3/4" BB form plywood laid over 4x4 or 4x6 wood joists spaced 6" to 16" on center. Both the plywood and joist should be checked for bending, shear, deflection and crushing. Where the bottom deck flares or thickens, the spacing of the joist can be reduced. It is usual practice to use only one selected joist member. This is because it is difficult to accommodate different depths of joists in the system.

Between the joist and the beam is commonly placed a camber strip. This camber strip is usually a triangular wedge that will keep the bottom deck on grade as the beam deflects under the weight of the bottom deck and stems plus the form and beam weights. The width of the camber strip is determined to prevent rolling and perpendicular to the grain timber crushing pressures from developing.

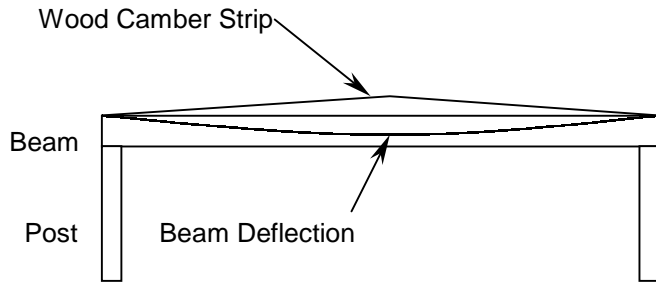

BEAM CAMBER STRIP

Often the project specifications limit design stress and deflections. I've seen L/D ratios ranging from 120 to 500.

If no specifications are given, common standards such as ASCE, UBC, ACI, or a definitive falsework manual should be used as a reference. The various members can be timber, steel, aluminum and concrete or any combination. Due to the large number of options and various specifications, this course will not recommend any stresses or deflections. The basic design considerations apply to any materials used.

Generally simple span beams are preferred for several reasons. Multiple span beams will not evenly distribute the loads to the supporting posts.

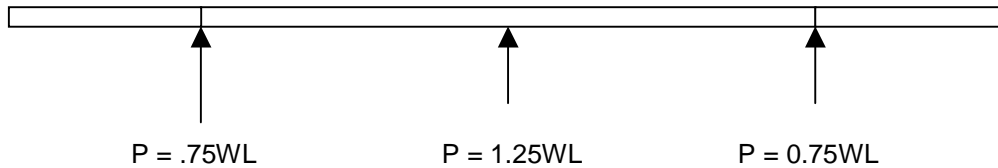

2 SPAN BEAM

There have been instances where long beams have contributed to falsework failures due to the pour sequence. In one case a heavy slab supported by 10K "Tinker Toy" shoring towers was caused to fail because the beam deflection in a partially completed pour transferred too much load to a tower leg. The leading end of the long beam actually lifted off the towers and transferred all the form and rebar weight to the leg under the leading edge of the concrete pour.

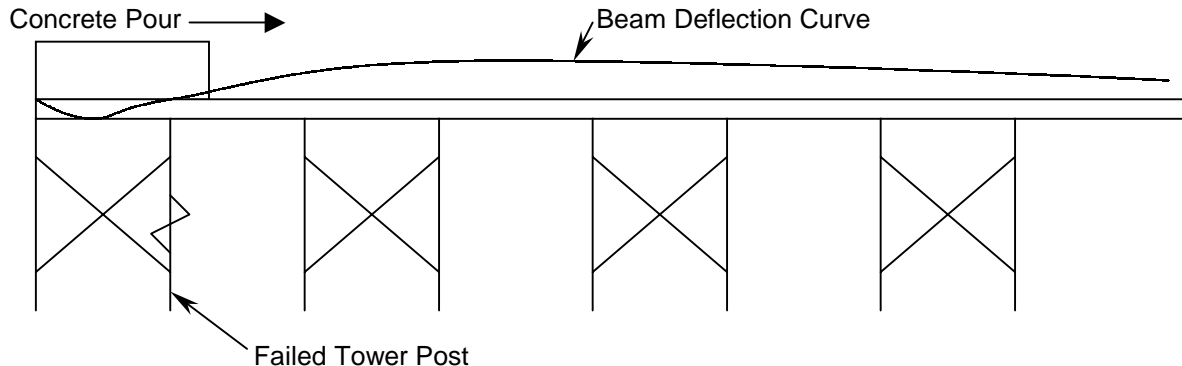

LONG SPAN DIAGRAM

In another case, overly long beams caused excessive settlement by transferring excessive load to the posts. Fortunately, this was discovered in time to prevent a collapse. The Posts were designed to support only the pour in progress. The pour in progress caused the tips of the beam to deflect upward and transferred the weight of the previous pours to the posts.

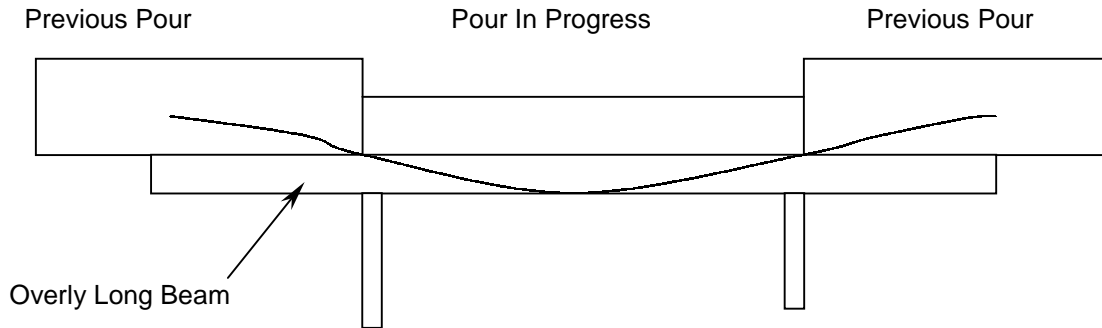

OVERLY LONG SIMPLE SPAN BEAM

Bridges are often designed with varying grades, curves and superelevation slopes. This creates several issues that must be resolved.

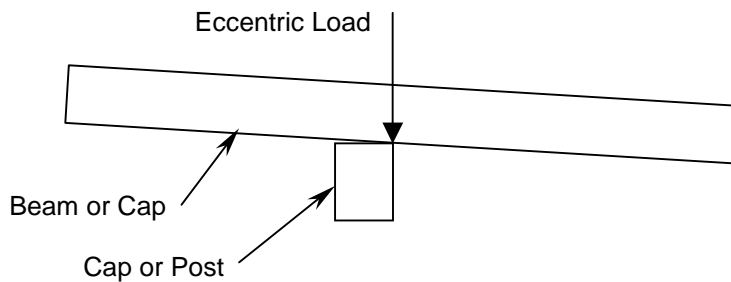

SUPERELEVATION & GRADE SLOPE DIAGRAM

The eccentric loading can cause lateral bending of the beams webs and induce bending moments into the posts. Wedging can be employed, but a two-way rocker bearing on the post is the preferred solution. Because the bridge bottom deck is commonly on a significant slope, squat and compact beams are preferred, such as a W14x90 shape. Because of the eccentric effects the bending stress of steel should be limited to 0.6 of the steel yield strength.

Lateral bracing should be used to keep the steel beams in a supported compact length. On severe transverse slopes the beams should be laterally supported at least near the supports and at mid-span. This can be easily accomplished with crossed 4x4 and steel banding.

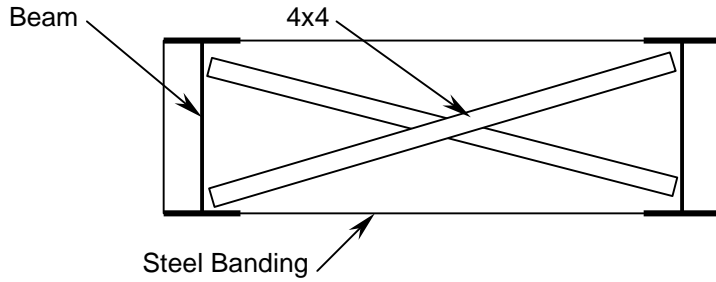

LATERAL BRACING OF BEAMS

Shear often controls the design of timber and concrete elements. Shear usually does not control the design of steel and aluminum beams. This is because the allowable shears stress of timber and concrete are on the order of 10% of the allowable compressive stress, while the allowable shear in steel and aluminum is on the order 50% of the allowable bending stress.

A significant consideration is web crippling of steel and aluminum shapes. It is expensive to install stiffeners and they must be accurately located. This limits the flexibility of the placement of crossing member as well as the reuse to another location. It is common to insert bearing plates between crossing beams to distribute the point loads. The plates are easily placed and make for an inexpensive solution to the web crippling issue.

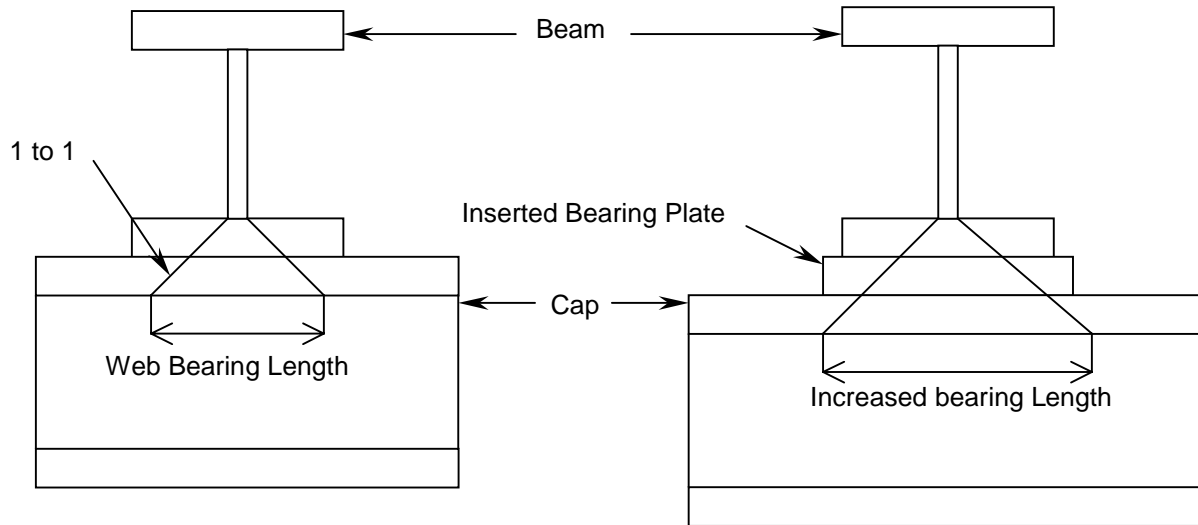

BEAM WEB CRIPPLING

PLATE ADDED TO INCREASE BEARING LENGTH

Timber crushing is a concern due to the fact that the perpendicular to the grain allowable bearing stress is on the order of 25 % of the parallel to the grain allowable bearing stress. Timber properties such as the modulus of elasticity and crushing resistance is greatly reduced by water saturation. It is recommended that the wet properties of timber be used for design criteria. Rain, clean up, and dust

control and curing water will likely soak into the timber members. Crushing of heavy timber, such as 12x12 can easily cause unacceptable settlements. I have seen such timber crush as much as 2 inches.

Just as steel plates can be used to distribute the web crippling loads in steel beams, plates can be easily inserted to distribute the crushing loads in timber beam to post connections. The added consideration is that the plate thickness must be designed to carry the distributed crushing load in bending.

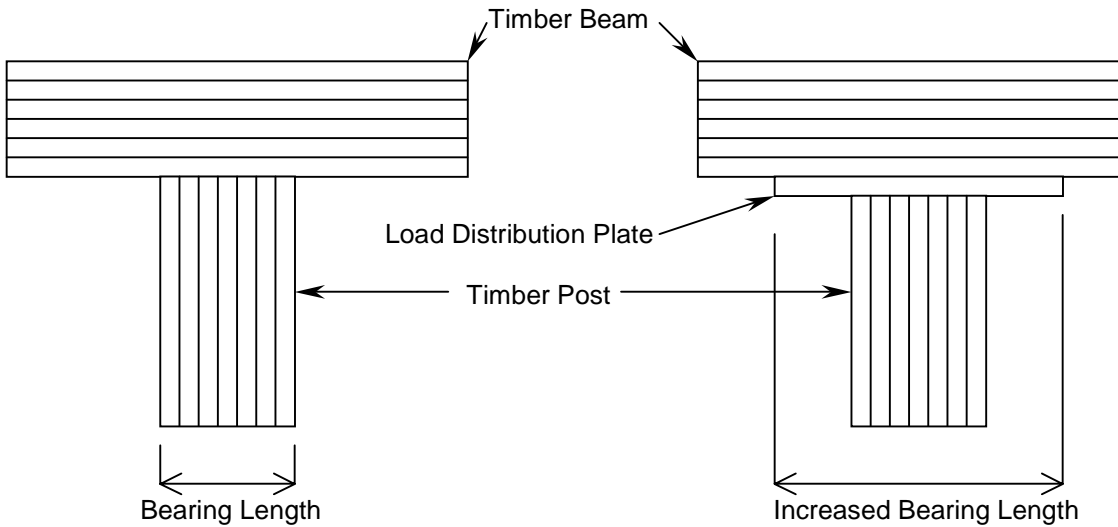

BEAM CRUSHING

PLATE ADDED TO INCREASE BEARING LENGTH

The falsework posts are usually designed to span full height without intermediate cross bracing to reduce cost and improve access. Cross bracing using cable is very effective. The cables can be attached to the cap and sub cap quickly and easily. For tall falsework steel pipes are commonly used. The long span posts should be designed to include a wind loading bending moment as well as the KL/R allowable stress reduction. The posts directly under the cable attachment point may require that the vertical component of the cable load be included as part of the column load if the bridge concrete is not laterally restrained at that stage of construction.

The posts should always be as vertically plumb as possible. Out of plumb posts can cause the falsework to over stress the cross bracing and collapse laterally as the initial concrete is being placed. The extent of such disaster is often massive with loss of crew and public lives. Under designing the cross bracing is the cause of many falsework failures.

A pipe or steel shape with a dent and/or a visible bow will have greatly reduced column strength. Severely checked or cracked timber will have reduced column and shear strength. All falsework structural elements must be true and in sound condition. Bowed or bent beams will cause great difficulty in establishing a uniform grade of the bottom deck soffit and may fail under load.

The sub cap serves several purposes. It anchors the cable cross bracing so that the entire falsework bent acts as a frame. If the cable is attached to a post, the lateral force can pull the post over causing a collapse of the falsework. The sub cap also aids in establishing the final soffit grade. Usually the falsework is erected an inch or two low and then jacked into final grade after the soffit plywood is installed. This also reduces the number of grade points. Trying to grade every beam end high in the air is a nearly hopeless task.

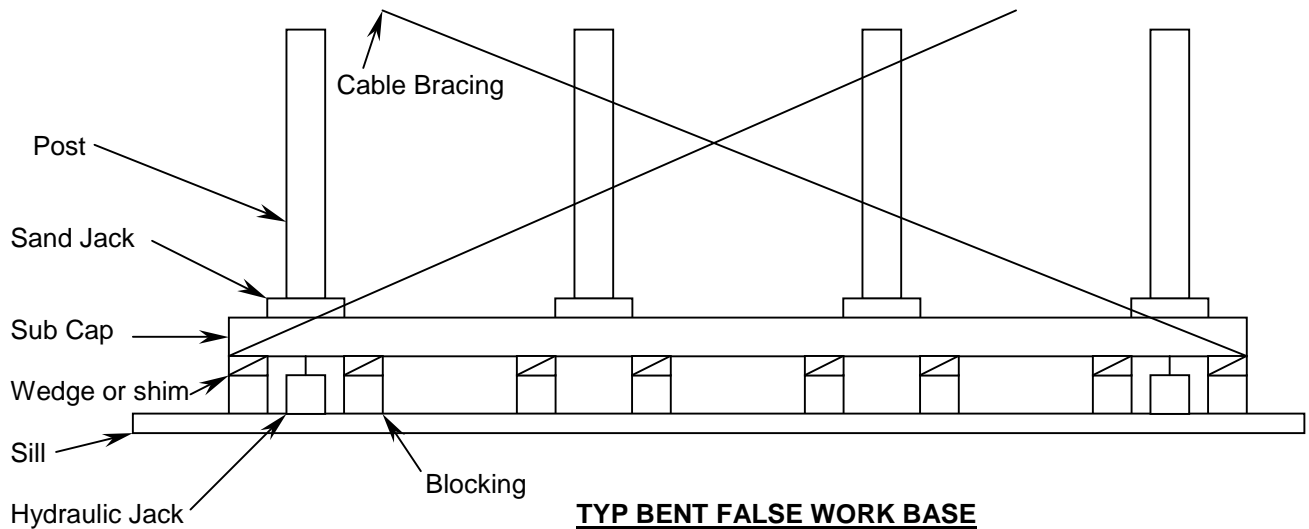

The sand jacks are not needed at all bents. At mid span the post-tensioned induced upward camber may be enough to release the bridge weight. At piers and especially at the hinge point a release mechanism is required to remove the bridge weight so that falsework can be easily stripped. A sand jack is a can containing sand. Removal of the can allows the sand to flow away and slowly lower the post to release the load.

There are a few precautions that should be considered when utilizing sand jacks. Clean sandblast type sand should be used. Once when we used dirty sand as filler, the rain and near by traffic vibration caused the clay and silt fines to wash out. This action allowed the falsework to settle about two inches. This nearly caused a collapse of the falsework.

Another time we designed sand jacks under posts supporting 200 tons each. The approximately 2,000 psi bearing pressure fused the sand to the point that it required the use of a jackhammer to break out the sand. The bearing pressure should be limited to about 750 psi. The sand jack should be fully covered by a steel plate designed to uniformly distribute the post load evenly over the entire sand surface.

The can should be designed to resist a lateral bursting pressure of at least 1/3 of the bearing pressure. The can should be tall enough so that 4 to 6 inches of release will be achieved and allow for a free flow of the sand. The cans may be made of wood, PVC pipe or steel, round or square.

The sub cap allows the soffit to be raised to final grade with only two jack points per falsework bent. Once final grade is established, the gap between the blocking and sub cap is packed with shims or wedges. The gap between the blocking and sub cap during jacking or release should always be minimal. Falsework collapses have occurred when the hydraulic jack failed and allowed a sudden drop of the falsework. During the jacking and release the falsework should be adequately braced laterally in all directions.

Double blocking is shown in the above diagram. This serves to reduce crushing pressure and more evenly distributes the loads on to the sill. This reduces the sill timber or concrete thickness.

The sill is usually a timber mat that uniformly distributes the falsework load uniformly to the soil. The soil conditions are very important. Soil conditions can vary from bent to bent. If some bents are founded on hard ground and some on soft ground, a disastrous differential settlement can occur. Sill sizes may require adjustment from bent to bent to cause a uniform ground deflection under all bents. In some

cases, the ground may be so weak that pile foundations may be required. These piles can often be "barkies", tree trunks with only the limbs removed. When falsework is installed over water or in a flood plane, expected water levels, currents and scouring should be considered. I have seen falsework collapse by floodwaters and swift currents. Currents often carry debris that will pile up against the falsework, causing significant lateral pressures. The lateral bracing should be designed to resist these forces. Often it is necessary to monitor any debris build up and remove the accumulation to prevent falsework collapse.

Consideration should be given to the soil type. Clay soils will soften when wet and that will cause added settlement. Usually that added settlement is differential and can lead to collapse. Proper drainage and covering the soil with Visqueen can be a solution to keep the soil dry. The project Geotechnical report may give an adequate description of the soil, if not then additional review and testing may be necessary to determine reasonable bearing pressures.

Joint preparation and solid bearing between structural members is very important. Joints that are not cut to fit properly will cause eccentric loading, crushing and at least unacceptable settlement, and can result in collapse.

All steel, timber, plywood, aluminum, concrete, rebar, bolts, cable and welds used in the construction of the should be specified by grade and code. Timber should be at least Construction grade and free of knots in any tension zone. Steel should be at least grade A36. High strength bolts should not be reused. Concrete should be designed for 7-day strength because it will probably not have time to cure for 28 days before being loaded. All structural components should be verified as to grade and suitability prior to installation.

As a side note, it is recommended that the decks be cured using spray on curing compounds and / or Visqueen.

We had a case where curing water leaked into the box girder cavity. The partial filling of the cavity caused excessive settlement. Drain holes in the bottom deck should be opened through the soffit to allow drainage of any accumulated water.

Settlement of the bridge results from a number of mechanisms:

- 1- Crushing and/or web crippling
- 2- Foreshortening of columns and compression of structural members.
- 3- Ground Compression

Most of the settlement is the result of take up of joints and ground settlement under full load. Well fitted timber joints will take up about 1/8 to 1/4 of an inch per joint and well fitted steel joints will take up about 1/32 to 1/16 of an inch per joint. Considering that there are 6 to 10 connections between the soffit and the ground, usually at least an inch of settlement can be attributed to joint take up. Twisted timbers and beams can easily double the expected settlement.

Ground settlement will vary from practically nothing on rock to an inch on soft ground. The design soil settlement pressure should limit settlement to about 1/2 inch to preclude dangerous differential settlements from occurring. The Geotechnical consultant can and should provide information regarding allowable soil bearing pressures.

Concrete K-Rail (Jersey Barrier) should be installed whenever traffic is expected to pass through or close to the falsework. A car or truck running into the falsework will ruin your entire day. Over height trucks can tear down falsework at traffic openings. Special warnings and alternate routes should be established when ever possible to prevent low overhead collisions.

Mistakes made during stripping of falsework have caused many disasters and casualties. This usually occurs when cross bracing or lateral support is improperly removed. Yanking out the posts has deliberately crashed Falsework. Crashing falsework is generally a poor practice since that action usually results in damage to the falsework materials and can result in other property damage. Crashing

falsework should never be done in close proximity to the public or traffic. The falsework design should include a procedure for dismantling.

The dismantling procedure can be the exact opposite of the erection process; again insuring the system is stabilized as each member is removed. An efficient way to strip is to suspend the soffit deck and beams from winches. First, cross brace the false work bents in pairs to create towers. Then raise the deck section a few inches. Slide the towers from under the structure and lower the deck sections to the ground. This allows most of the dismantling process to have efficient ground level and crane access.