

# Small Motor Control (1/4 HP – 200 HP)

*Thomas Mason, P.E.*

## Course Content

With some exceptions, motor control is performed by the combination of a very few devices, as follows:

- Power disconnect switch
  - Instantaneous overcurrent protection
  - Long-time overload protection
  - Hand-Off-Auto selector switch
- or,
- Start-Stop pushbuttons
- and, sometimes,
- External emergency-stops, interlocks and permissives
  - Auxiliary contacts
  - Control power is required or desirable on most control circuits
  - Starter NEMA Sizes
  - Starter NEMA Enclosures

Each of these devices is discussed below, with demonstration drawings. There is an ANSI standard for drawing symbols, but those used below are typical of commercial use and consistent with the National Electrical Code.

**Power disconnect switch:** On the smallest fractional horsepower motors, a plug and receptacle can act as a power disconnect switch. Even on very small motors, it is desirable to use an enclosed motor-rated switch. This switch can be stand-alone in a separate box, combined with a fuse, combined into a thermal-magnetic circuit breaker, combined with a motor overload device or included in a combination motor starter. (Combination motor starter means a combination of disconnect switch, protection and start-stop control, in a single enclosure.)

**Instantaneous overcurrent protection:** Short-circuit protection is required for the wires between the controls and the motor. This is provided by the fast-acting portion of a fuse or the magnetic portion of a circuit breaker. Because of the inductive inrush and start-up inertial acceleration of the motor, instantaneous protection is set well above the running-rating of the motor.

**Long-time overload protection:** Very small motors are self-protected, usually containing a winding thermostat (brand name Klixon) which disconnects power when excessive heat is generated. Even small motors are better protected by external motor overload protective relays, normally called "overloads". For this discussion, mechanical overload protective relays will be discussed, though the function is being replaced by solid-state devices, sometimes incorporated in "Smart" motor starters. Overloads have a heater and time-temperature characteristic on the relay contacts. Very-high short term overloads are permitted for inrush and acceleration but long-term trip is promised at a value very close to the motor full-load rating. Replaceable heaters assure that the adjustment is available. Improper overloads, usually caused by lack of care in selection, cause false motor-trips or motor failure without shutdown.

**Hand-Off-Auto selector switch:** The operator must start the motor, either individually, or as part of a sequence. A Hand-Off-Auto selector switch meets this need well. Off is the not-running position. (However, OSHA requires that the power disconnect switch be opened and sometimes locked out.) In the Hand position, the motor runs. (A major controversy rages on whether safeties, interlocks and permissives are bypassed in Hand. Greatest safety and lowest design

liability exist when safeties, interlocks and permissive are left in the circuit. Maintenance becomes more difficult.) In the Auto position, a external switch, relay, PLC or other external device starts the motor. In both Hand and Auto, the motor runs until a controlled stop command is received, the power disconnect is opened or the overload trips.

**Start-Stop pushbuttons:** Pushbuttons normally indicate local operator control. However, a remote relay contact may be wired in parallel with the local Start pushbutton. Similarly, a remote normally-closed contact may be wired in series with the local Stop button. Both Starts work. Both Stops work. Either Stop overrides either start. There is a potential for unexpected operation unless a maintained local stop button is used. OSHA requires that the power disconnect switch be used during maintenance, though some Owners still require lockable Stop buttons.

**External emergency-stops, interlocks and permissives:** For this discussion, normal operation is commanded via the H-O-A control circuit or the Start-Stop control circuit. A separate class of controls operates only during abnormal conditions. An Emergency Stop button, a trip wire or a light curtain stop the machine for personnel safety reasons. By the National Electric Code, these E-Stops must be in the control circuit before the H-O-A or Start-Stop. CAUTION: many designers do not realize this and place the E-Stop after the H-O-A switch.

Interlocks and permissives refer to the sequence of operations among multiple motors or devices. Formally, Interlocks are commands to downstream motors and permissives are commands received from upstream devices. The terms, however, are used loosely in the field. For a series of conveyors, #1 which feeds #2 and #2 feeds #3. We will look at the middle unit, #2. Before #2 can start, #3 should be running to assure there is a place to deposit the contents of #2. Therefore an auxiliary motor start contact from the #3 starter is connected into #2 as a permissive before the normal controls. When #2 is running, it is OK to start #1, so an auxiliary contact from the #2 motor starter is used to interlock #1, before the normal controls. Interlocks and permissives can also be pressure switches, thermostats or time-delay relays. Obviously, this function is rapidly migrating to PLC's.

**Auxiliary contacts:** The relay which is used to start and stop the motor must have heavy-duty power contacts to close on inrush current and break inductive current when the motor stops. It is common to provide small, pilot-duty contacts on the same relay for control purposes. [Pilot-duty applies to 120V, 5A contacts which will operate all but the largest motor contactors. Motor-rated is the term for 480V, 20A contacts which will carry inrush and interrupt inductive current. Reed-relays, rated 24V, 1A are sometimes provided with Programmable Logic Controllers (PLC's).]

**Control power:** Many years ago, the motor power leads were tapped and connected to the H-O-A selector or Start-Stop pushbuttons and to a line-voltage motor relay (contactor). This is still permitted, with severe limitations. Years later, with the advent of motor control centers, it became common to include a lighting/control transformer and distribution panel in one vertical section. The panel provided 120V control power to the motor starters. UL made this impractical by requiring a control power disconnect along with the main power disconnect. A remnant remains in a rare requirement for power disconnect switches at the motor which contain a control power interlock switch for the starter. The standard today is for two fuses connected to the motor power leads after the power disconnect, a control transformer, a grounded leg and a fused control leg. An oversize control transformer is required if indicator lights and auxiliary relays are used.

## **The National Electrical Code**

The organization of the 2002 National Electric Code is as follows:

Introduction 80 - Administration [not enforceable Code]

Introduction 90 - Introduction [valuable discussion but not enforceable Code]

Chapter 1, Section 100 - Definitions [extremely valuable and enforceable]

- Chapter 1, Section 110 - Requirements [requires reading and re-reading; enforceable]  
 Chapter 2 – Wiring and Protection [see annotated Table of Contents - separate PDHonline course]  
 Chapter 3 - Wiring Methods [Definitions of rigid and flexible conduits and open power wiring and limitations]  
 Chapter 4 - Equipment for General Use [Flexible cords, switches, panels, lighting and much more]  
**Section 430 - Motors and Motor Control**  
 Chapter 5 – Special Occupancies [hazardous areas, garages, health care, theaters and more]  
 Chapter 6 - Special Equipment [signs, hoists, elevators, information technology and more]  
 Chapter 7 - Special Conditions [Emergency generators, low-voltage wiring, fire alarm wiring and more]  
 Chapter 8 - Communications Systems [radio, tv, powered data circuits and more]  
 Chapter 9 - Tables  
 Annexes, formerly appendices [not enforceable]

**Starter NEMA Sizes**

460V Motor or HP	NEMA Starter Size
10	1
25	2
50	3
100	4
200	5

**Starter NEMA Enclosures**

NEMA Enclosure	Application	Comment
1	Indoor General Purpose; Tests: rod entry, rust	Common Commercial Use
3R	Outdoor Raintight; Tests: rain, rod entry, icing, rust	Commercial and Industrial
4X	Corrosion Resistant, Indoor, Outdoor; Tests: hose-directed salt spray, blown dust, rain, corrosion (Stainless Steel)	
7	Explosion-Proof	Identify Hazardous Class, Division and Group
12X	Corrosion Resistant; Premium 4X, often RRP	

### Simplified Three-Wire Diagram

The power circuit for motor control is shown below. It is important to become familiar with the terminology, as it is the basis for regulations listed in NFPA 70, the National Electric Code.

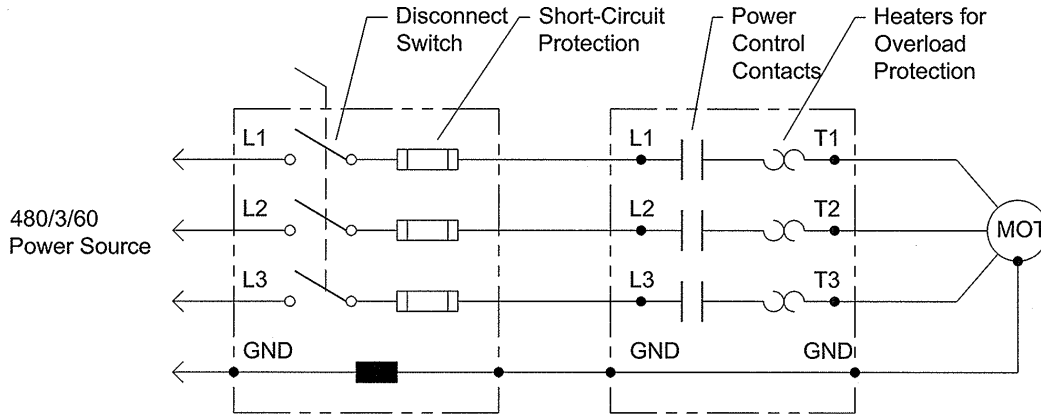

### Simplified Three-Wire Diagram

similar to NEC Handbook Exhibit 430.2

### Manual Motor Starter

The complete diagram for a simple manual motor starter is shown below. This form is economic, reliable and maintainable. The disconnect must be lockable and within sight of the motor. This is a common situation in air conditioning machine rooms.

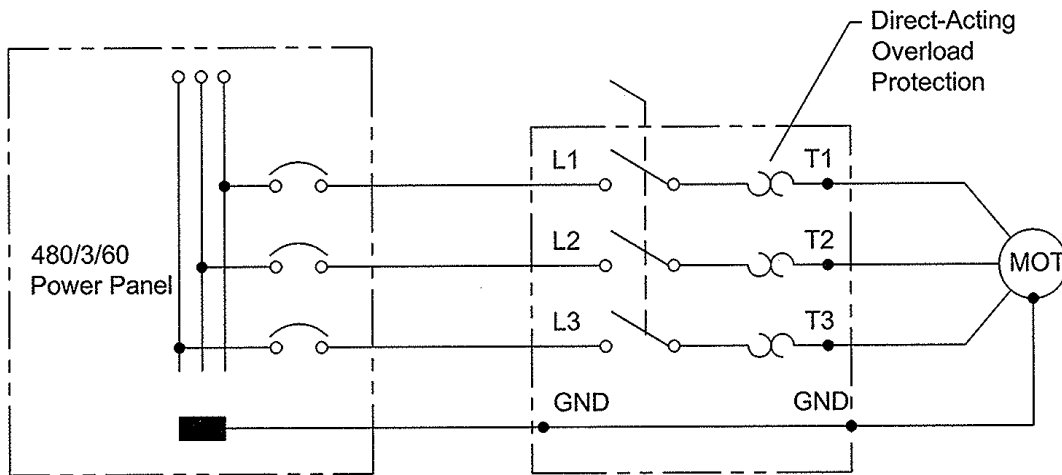

### Manual Motor Starter Three-Wire Diagram

similar to NEC Handbook Exhibit 430.2

## Combination Starter with H-O-A Selector

Below, please note the complete diagram for a combination starter with Hand-Off-Auto selector switch and remote Emergency Stop, permissive and computer control. Such diagrams were formerly provided in catalogs from General Electric, Westinghouse, Square D and Cutler-Hammer. This diagram is a bit more detailed, including the ground power conductor and notation for remotely located devices. The H-O-A and indicators are located in the front of the starter. The overload heaters are part of the overload protective relay. This form is no longer the economic choice, as integrated IEC units are legal and reliable when properly applied, much smaller and less expensive. The components in the IEC unit are identical, but less accessible and not visibly obvious.

The control portion of this diagram is called a "ladder diagram" due to its form. Through the early days of programmable logic controllers (PLC's), this was the universal expression of motor control. With a little experience, the logic of the controls can be followed and a voltage tester can verify operation for maintenance. Project Managers, Chemical Engineers and Mechanical Engineers could participate in controls design and review.

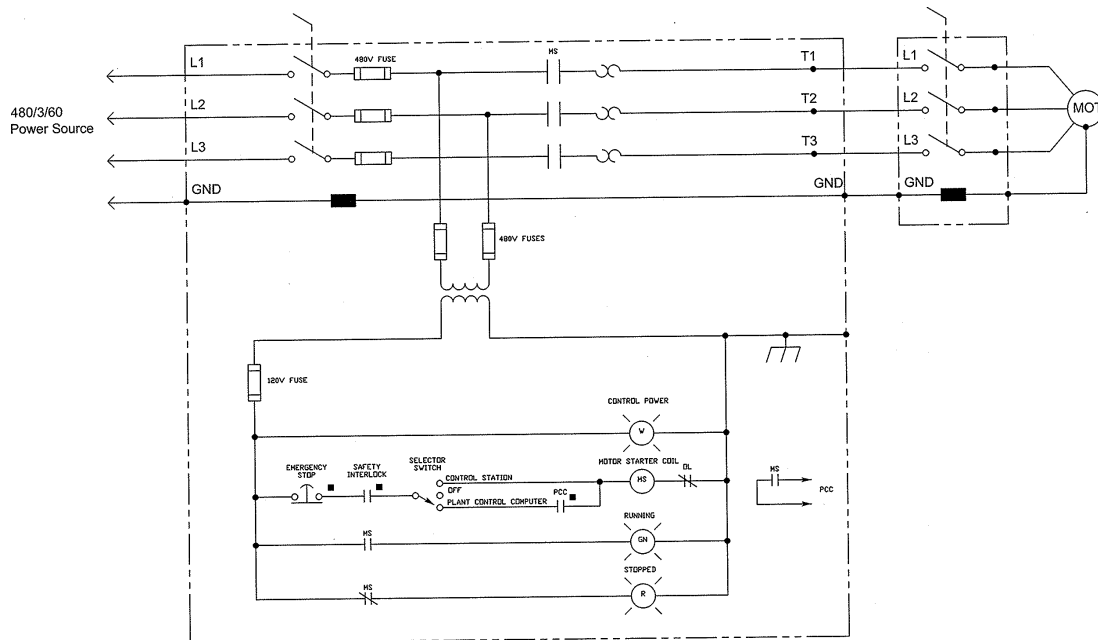

**Detailed Three-Wire Power and Ladder Control Diagram**

similar to NEC Handbook Exhibit 430.2

■ = device located outside motor starter enclosure

## Combination Starter with H-O-A Selector and Remote Start-Stop

Below is the complete power and control diagram for a combination motor starter with H-O-A in the starter and remote Start-Stop pushbutton station with status lights. This form demonstrates use of an auxiliary relay for conversion of momentary control to maintained control, called seal-in. The diagram shown was actually used at a large chemical plant constructed in the 1980's. It is valuable to follow current flow with a finger and postulate results of a ground-fault at each point. This approved circuit is fail-safe, that is, an open or cross fault cause shutdown, not uncontrolled operation.

This control circuit is a bit peculiar. Most large industrial firms and utilities require standard control circuits which can be very peculiar. Many survive from the 1980's and before, so understanding the

logic is relevant and the finger-testing method still works on the power components of the control circuit.

The control relay costs more than a commodity PLC. The replacement PLC permits remote monitoring, alarming and interlocking at no substantial cost. Controls vendors encourage purchase of “smart” motor starters, which incorporate electronic overloads, proprietary data communications and features added frequently. Solid-state contactor are offered, with soft-start. Initial cost is competitive with electromechanical controls. Startup must be performed by a skilled technician. In rare cases, plant electricians are trained to perform troubleshooting.

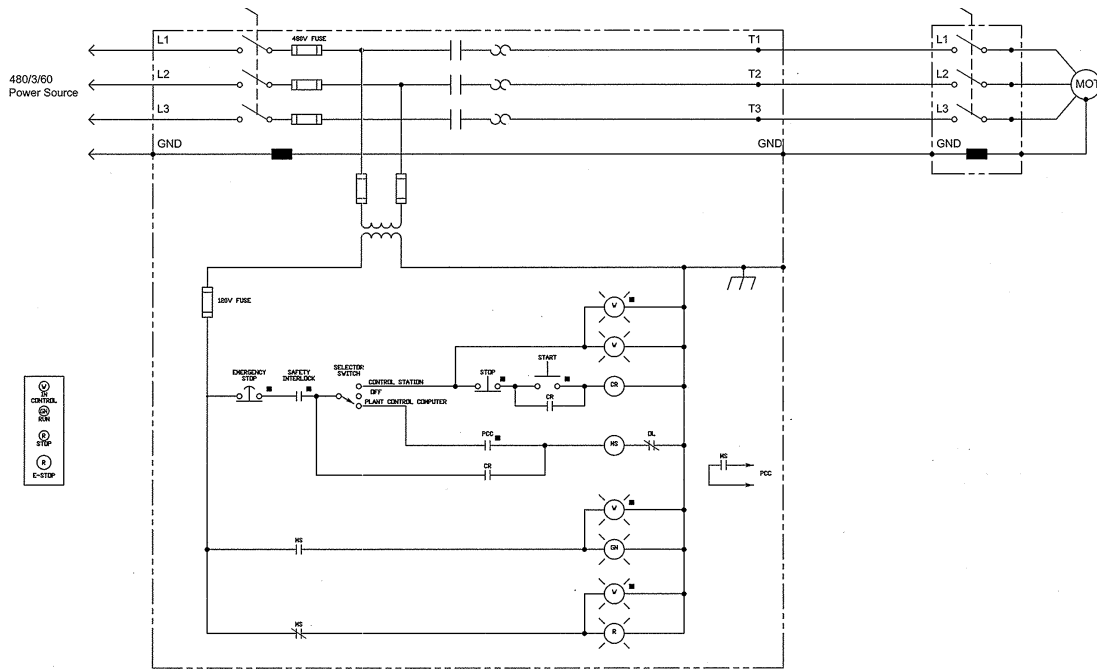

Detailed Three-Wire Power and Ladder Control Diagram

similar to NEC Handbook Exhibit 430.2

## Automatic Motor Control

A simple pump requires safety interlocks. The previous discussions apply. A complex machine, such as an elevator or crane control is much more complex. Industrial machine controls are complex. Electromechanical controls were very complex. Electronic controls are even more complex, as regulations continue to grow. The difficulty of reviewing the power connections for a modern control system is real. The difficulty of reviewing the software logic is substantial for skilled programmers. Neither the power side nor the software side of computerized motor control is addressed here. NFPA 79, Electrical Standard for Industrial Machinery provides standards for such modern motor control.

## NFPA 79, Electrical Standard for Industrial Machinery Table of Contents

- Ch 1 - Administration
- Ch 2 - Referenced Publications
- Ch 3 - Definitions
- Ch 4 - General Operating Conditions
- Ch 5 - Incoming Supply Circuit Conductor Terminations and Devices for Disconnect

Ch 6 - Protection from Electric Shock  
Ch 7 - Protection of Equipment  
Ch 8 - Grounding  
Ch 9 - Control Circuits and Control Functions  
Ch 10 - Operator Interface and Control Devices  
Ch 11 - Electronic Equipment  
Ch 12 - Control Equipment: Location, Mounting, and Enclosures  
Ch 13 - Conductors, Cables, and Flexible Cords  
Ch 14 - Wiring Practices  
Ch 15 - Electric Motors and Associated Equipment  
Ch 16 - Accessories and Lighting  
Ch 17 - Marking and Safety Signs  
Ch 18 - Technical Documentation  
Ch 19 - Testing and Verification  
Annex A - Explanatory Material  
Annex B - Inquiry form for Electrical Equipment of Machines  
Annex C - Examples of Industrial Machines Covered by NFPA 79  
Annex D - Technical Documentation  
Annex E - Device and Component Designations  
Annex F - Electrical Enclosure Ratings: Type-Ratings Versus IP-Rating  
Annex G - Kilowatt Outputs with Horsepower Equivalents  
Annex H - Cross-Reference Tables  
Annex I - Minimizing the Probability of Control function Failure  
Annex J - Informational References  
Index