

# **Power Systems - Basic Concepts and Applications**

## **Part II**

By Shih-Min Hsu, Ph.D., P.E.

## MODULE 5: Power Flow Problems and Solutions.

### Overview

In general, a power system is very complicated physically, and power flow problems can not be solved as a linear system. Its solution is not easy to solve mathematically, and is only possible by numerical iterations. Although there are a number of methods to solve power flow problems, Newton-Raphson method is presented in this module.

### Basic Settings

Although power systems are designed and operated in a three-phase form, because of the important feature of the three-phase system – symmetry, a per phase analysis is usually performed. Moreover, one-line (single-line) diagrams are used for power system representations. The IEEE 25-bus test system is shown in Figure 5-1, and is represented as a one-line diagram.

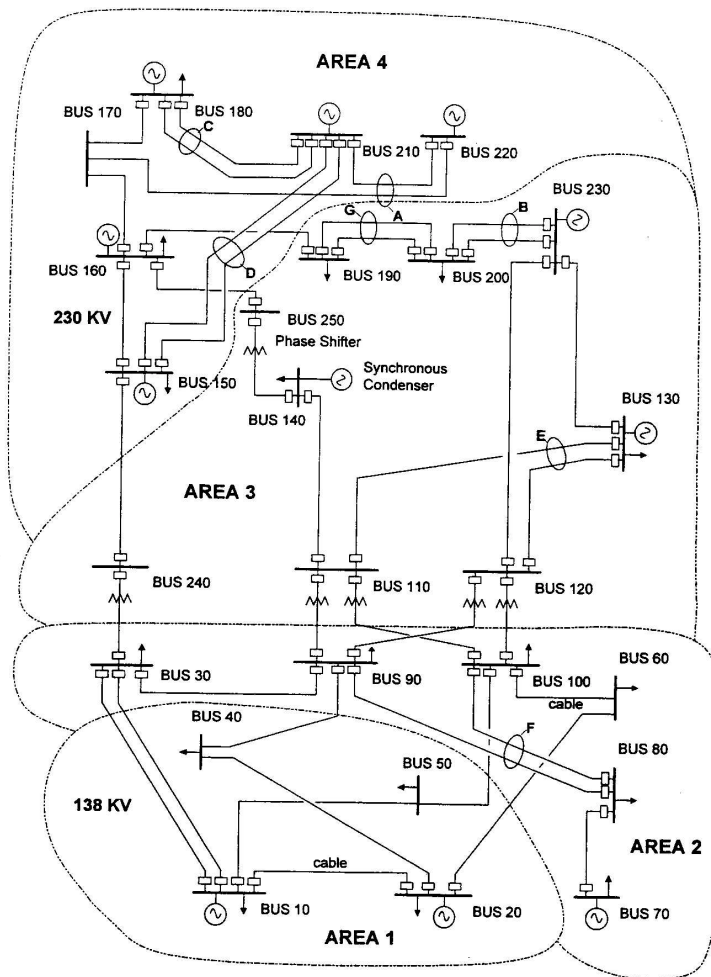

Fig. 5-1. IEEE 25-bus test system.

Commonly, instead of a “node” in circuit analysis, a “bus” is used for power flow problems. There are three types of buses in power systems:

- (1) Load buses – Loads, including active and reactive powers, are connected to load buses and are known. However, their voltage magnitudes and phase angles are unknown.
- (2) Generator buses – Generators are connected to generator buses and the active power generated and voltage magnitude are predetermined at each generator bus. If the reactive power required for holding the specified voltage is within its limits, such a voltage will be maintained. Otherwise, the reactive power generation will be set at the limit and the voltage magnitude becomes a variable. Generator buses are also called voltage-controlled buses.
- (3) Slack/swing bus – With single area system, the slack/swing bus has a generator connected, and the scheduled voltage magnitude and phase angle are fixed for the power flow calculation. Usually a larger unit is used for slack/swing bus since such a unit has variable active power and reactive power outputs to pick up some extra losses when needed. If the system has multiple areas, a slack bus is needed for each area while only one swing bus exists for the entire system. The active power and reactive power at slack/swing bus are to be determined.

To summarize the known and unknown parameters at three types of buses, Table 5-1 can be used.

Table 5-1. Typical known and unknown parameters at three types of buses:

	V	$\delta$	P	Q
Slack/swing buses	Known	Known	Unknown	Unknown
Generator buses	Known	Unknown	Known	Unknown
Load buses	Unknown	Unknown	Known	Known

In general situations, any bus can have a number of generators, transmission lines and loads connected, as shown in Figure 5-2. By Kirchhoff’s current law (KCL), the currents at bus  $i$  have the following relationship:

$$\bar{I}_{Gi} = \bar{I}_{Li} + \bar{I}_{Ti}$$

One can take the conjugate of the currents on both sides and multiple the voltage at bus  $i$  on both sides, then, the relationship on complex power can be obtained, namely,

$$\bar{S}_{Gi} = \bar{S}_{Li} + \bar{S}_{Ti}$$

where

$\bar{S}_{Gi}$  is the total three-phase complex power generated at bus  $i$ ,

$\bar{S}_{Li}$  is the total load complex power at bus  $i$ ,

and

$\bar{S}_{Ti}$  is the total complex power flowing out of bus  $i$ .

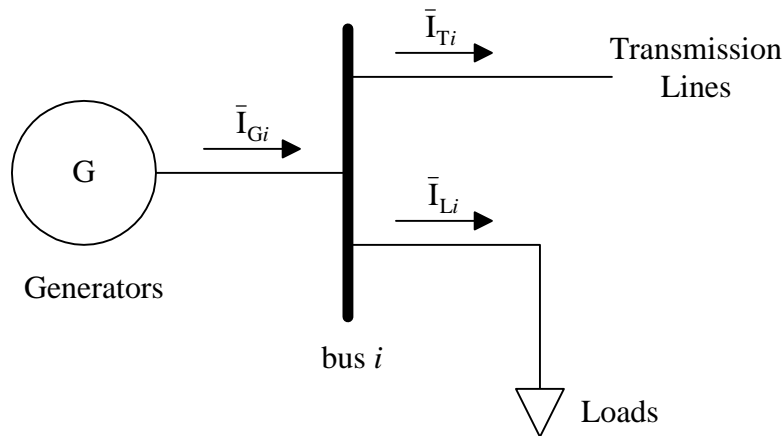

Fig. 5-2. One-line diagram at bus  $i$ .

Then, one may separate the real and imaginary parts of the generated complex power. Two set of equations, one for active power and one for reactive power, can be obtained as follows

$$P_{Gi} = P_{Li} + P_{Ti},$$

and

$$Q_{Gi} = Q_{Li} + Q_{Ti}.$$

As tabulated in Table 5-1, the load active power and reactive power are usually known. The generator active power is known while the reactive power production is related to its scheduled voltage. Therefore, the main concern is on the complex power, or current, flowing out of the bus  $i$ . There are two main approaches to solve power flow problems. The first one is the impedance approach, since

$$[\tilde{V}] = [\tilde{Z}][\tilde{I}_T],$$

while the second one is the admittance approach,

$$[\tilde{I}_T] = [\tilde{Y}][\tilde{V}],$$

where

$[\tilde{I}_T]$  is an  $n \times 1$  current vector ( $n$  is the total number of buses in the system) with a general entry of  $\bar{I}_{Ti}$  (the current injection at bus  $i$ ),

$[\tilde{V}]$  is an  $n \times 1$  voltage vector with a general entry of

$$\bar{V}_i = V_i \angle \delta_i,$$

and

$[\tilde{Y}]$  is an  $n \times n$  matrix and is called the bus admittance matrix with a general entry as follows

$$\bar{y}_{ij} = y_{ij} \angle \gamma_{ij} = g_{ij} + jb_{ij}.$$

Since the admittance approach will be discussed in this module, the fundamentals of the bus admittance matrix are presented next.

## Bus Admittance Matrix

To learn more about the bus admittance matrix, the equation above with  $[\tilde{Y}]$  can be re-written as follows

$$\begin{bmatrix} \bar{I}_1 \\ \bar{I}_2 \\ \vdots \\ \bar{I}_n \end{bmatrix} = \begin{bmatrix} \bar{y}_{11} & \bar{y}_{12} & \cdots & \bar{y}_{1n} \\ \bar{y}_{21} & \bar{y}_{22} & \cdots & \bar{y}_{2n} \\ \vdots & \vdots & \ddots & \vdots \\ \bar{y}_{n1} & \bar{y}_{n2} & \cdots & \bar{y}_{nn} \end{bmatrix} \begin{bmatrix} \bar{V}_1 \\ \bar{V}_2 \\ \vdots \\ \bar{V}_n \end{bmatrix}.$$

The bus admittance matrix has the following properties:

- (1) It is symmetric.
- (2)  $\bar{y}_{ii}$ , the self-admittance (diagonal element), is equal to the sum of the admittances of all the components connected to the  $i$ th bus.
- (3)  $\bar{y}_{ij}$ , the  $ij$ th element (off-diagonal element), is equal to the negative of the admittance of the all components connected between buses  $i$  and  $j$ . It is worth mentioning that if more than one component is connected in parallel between the two buses, the equivalent admittance of the components should be first obtained before determining the entry in  $[\tilde{Y}]$ .

The bus admittance matrix building algorithm:

$$\bar{y}_{ii} = \text{sum of all admittances connected to bus } i.$$

$$\bar{y}_{ij} = - \text{admittance connected between buses } i \text{ and } j \text{ where } i \neq j.$$

Example 5-1: A 3-bus system as shown in Figure 5-3, find the bus admittance matrix. The line impedances given as  $\bar{Z}_a = j0.6$ ,  $\bar{Z}_b = j0.2$  and  $j0.25$  pu.

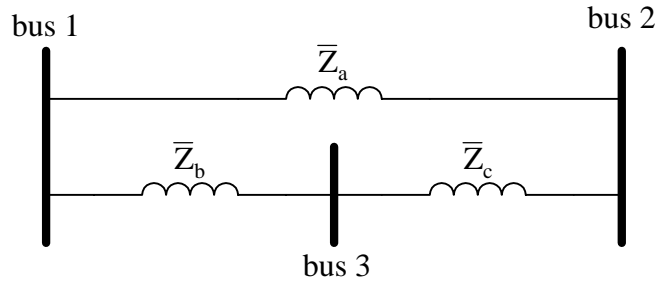

Fig. 5-3. Three bus system for building bus admittance matrix.

Solution:

First of all, convert all impedances to admittances, therefore,

$$\bar{Y}_a = \frac{1}{\bar{Z}_a} = -j1.67$$

$$\bar{Y}_b = \frac{1}{\bar{Z}_b} = -j5$$

$$\bar{Y}_c = \frac{1}{\bar{Z}_c} = -j4$$

For the diagonal elements,

$$\bar{y}_{11} = \bar{Y}_a + \bar{Y}_b = -j1.67 + (-j5) = -j6.67$$

$$\bar{y}_{22} = \bar{Y}_a + \bar{Y}_c = -j1.67 + (-j4) = -j5.67$$

$$\bar{y}_{33} = \bar{Y}_b + \bar{Y}_c = -j5 + (-j4) = -j9$$

For the off-diagonal elements,

$$\bar{y}_{12} = -(\bar{Y}_a) = -(-j1.67) = j1.67 = \bar{y}_{21}$$

$$\bar{y}_{13} = -(\bar{Y}_b) = -(-j5) = j5 = \bar{y}_{31}$$

$$\bar{y}_{23} = -(\bar{Y}_c) = -(-j4) = j4 = \bar{y}_{32}$$

Therefore, the bus admittance matrix for the simple system can be obtained as follows

$$[\tilde{Y}] = \begin{bmatrix} \bar{y}_{11} & \bar{y}_{12} & \bar{y}_{13} \\ \bar{y}_{21} & \bar{y}_{22} & \bar{y}_{23} \\ \bar{y}_{31} & \bar{y}_{32} & \bar{y}_{33} \end{bmatrix} = \begin{bmatrix} -j6.67 & j1.67 & j5 \\ j1.67 & -j5.67 & j4 \\ j5 & j4 & -j9 \end{bmatrix}$$

◆

Example 5-2: A 3-bus system, as shown in Figure 5-4, find the bus admittance matrix. The three transmission lines are assumed to be identical with the following line parameters:  $\bar{Z} = j0.1$ , and  $\frac{\bar{Y}}{2} = j0.01$ .

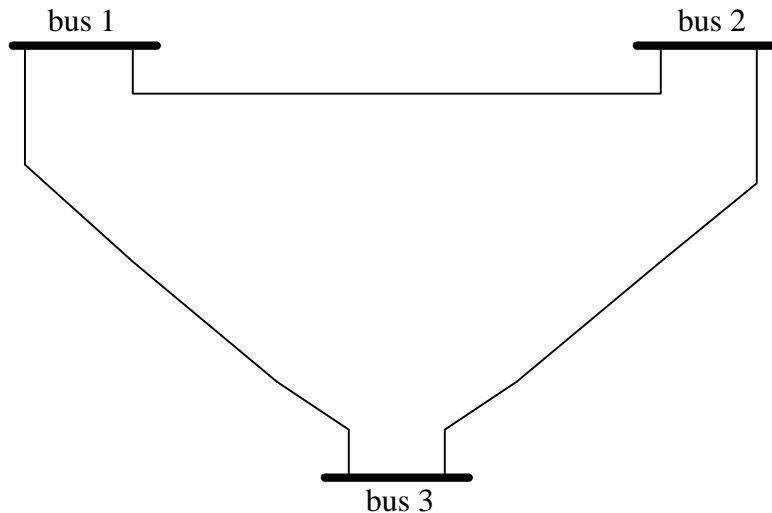

Fig. 5-4. Three bus system for building bus admittance matrix.

Solution:

Recall the transmission line model, the impedance  $\bar{Z}$  is the series component, and the admittance  $\frac{\bar{Y}}{2}$  is the shunt component at each end. To construct the bus admittance, a diagram including all series and shunt components, as shown in Figure 5-5, can be helpful. As mentioned earlier, one may want to combine the parallel elements before building the bus admittance matrix. Therefore the two shunt elements at each bus can be equivalent into one element with an admittance of  $j0.02$ . Also, the series impedance needs to be converted into admittance.

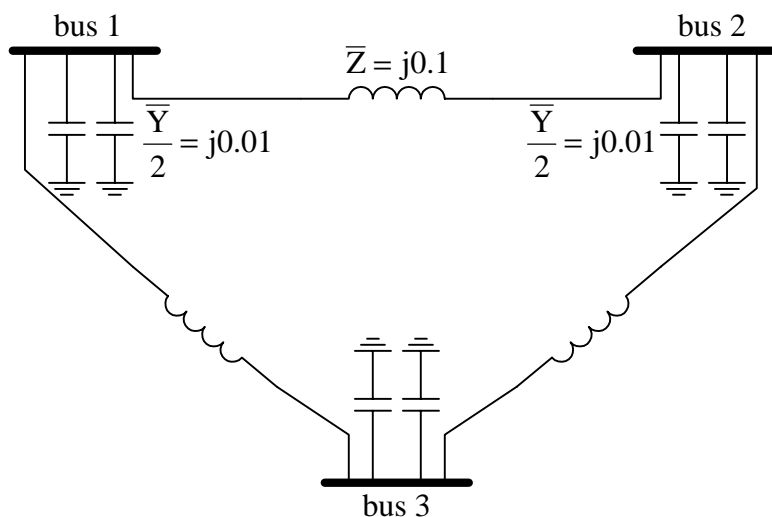

Fig. 5-5. Modified 3-bus system with all series and shunt elements represented.

Therefore, the bus admittance matrix for the simple system can be obtained as follows

$$[\tilde{Y}] = \begin{bmatrix} -j20 + j0.02 & -(-j10) & -(-j10) \\ -(-j10) & -j20 + j0.02 & -(-j10) \\ -(-j10) & -(-j10) & -j20 + j0.02 \end{bmatrix} = \begin{bmatrix} -j19.98 & j10 & j10 \\ j10 & -j19.98 & j10 \\ j10 & j10 & -j19.98 \end{bmatrix}$$

◆

When add/remove (switch on/off) a line to/from an existing system with its bus admittance matrix obtained, it would be troublesome if one needs to construct the whole thing over again. To add (switch on) an element,  $\bar{y}_k$ , terminated at buses  $i$  and  $j$ , four entries in  $[\tilde{Y}]$  will be affected, namely,  $\bar{y}_{ii}$ ,  $\bar{y}_{jj}$ ,  $\bar{y}_{ij}$  and  $\bar{y}_{ji}$ . The new values of the four entries can be calculated as follows

$$\bar{y}_{ii,\text{new}} = \bar{y}_{ii,\text{old}} + \bar{y}_k,$$

$$\bar{y}_{jj,\text{new}} = \bar{y}_{jj,\text{old}} + \bar{y}_k,$$

$$\bar{y}_{ij,\text{new}} = \bar{y}_{ij,\text{old}} - \bar{y}_k,$$

$$\bar{y}_{ji,\text{new}} = \bar{y}_{ji,\text{old}} - \bar{y}_k.$$

To remove (switch off) an element, simply add  $(-\bar{y}_k)$ , instead of add  $\bar{y}_k$ , with the same procedure as adding an element. The above discussion should be applied when the transmission line model with only series component is assumed.

Example 5-3: For the same three bus system as given in Example 5-1, if the line between buses 1 and 2 is out for maintenance, what is the new bus admittance matrix?

Solution:

The bus admittance matrix with all elements in service was obtained, and

$$[\tilde{Y}_{\text{old}}] = \begin{bmatrix} -j6.67 & j1.67 & j5 \\ j1.67 & -j5.67 & j4 \\ j5 & j4 & -j9 \end{bmatrix}$$

With the line out for maintenance, one can apply the procedure introduced for adding a line but with a  $(-\bar{y}_k)$ , namely,

$$\bar{y}_{11,\text{new}} = \bar{y}_{11,\text{old}} + (-\bar{y}_k) = -j6.67 + j1.67 = -j5$$

$$\bar{y}_{22,\text{new}} = \bar{y}_{22,\text{old}} + (-\bar{y}_k) = -j5.67 + j1.67 = -j4$$

$$\bar{y}_{12,\text{new}} = \bar{y}_{12,\text{old}} - (-\bar{y}_k) = j1.67 - j1.67 = 0 = \bar{y}_{21,\text{new}}$$

Therefore, the new bus admittance matrix with the line between buses 1 and 2 out for maintenance can be obtained as

$$[\tilde{Y}_{\text{new}}] = \begin{bmatrix} -j5 & 0 & j5 \\ 0 & -j4 & j4 \\ j5 & j4 & -j9 \end{bmatrix}$$

If one constructs the bus admittance with only elements  $\bar{Z}_b$  and  $\bar{Z}_c$ , the same bus admittance matrix could be obtained. ♦

Example 5-4: The bus admittance matrix of a power system changed from  $[\tilde{Y}]$  to  $[\tilde{Y}_{\text{new}}]$  after the occurrence of a line switching.

- (1) Which line (between which two buses) does the switching occur?
- (2) Is the line switching a line outage or a reclosure?
- (3) What is the line impedance value?

$$[\tilde{Y}] = -j \begin{bmatrix} 20 & -5 & 0 & -6 & -4 \\ -5 & 40 & -10 & 0 & 0 \\ 0 & -10 & 50 & -15 & 0 \\ -6 & 0 & -15 & 40 & -14 \\ -4 & 0 & 0 & -14 & 20 \end{bmatrix}, [\tilde{Y}_{\text{new}}] = -j \begin{bmatrix} 20 & -5 & 0 & -6 & -4 \\ -5 & 60 & -10 & 0 & -20 \\ 0 & -10 & 50 & -15 & 0 \\ -6 & 0 & -15 & 40 & -14 \\ -4 & -20 & 0 & -14 & 40 \end{bmatrix}.$$

Solution:

- (1) By comparing the two bus admittance matrices, one can find that only four entries are different from each other, namely,  $\bar{y}_{22}$ ,  $\bar{y}_{55}$ ,  $\bar{y}_{25}$  and  $\bar{y}_{52}$ . Therefore, the switching occurs on the line between buses 2 and 5.

- (2) Assume it is a line reclosure (adding a new element).  $\bar{y}_{22,\text{new}} = \bar{y}_{22,\text{old}} + (\bar{y}_k)$ , therefore,

$$\bar{y}_k = \bar{y}_{22,\text{new}} - \bar{y}_{22,\text{old}} = -j60 - (-j40) = -j20$$

Since the line admittance is negative, the assumption of a line reclosure is correct. If the admittance obtained under this assumption, then, a line opening would be the right answer.

- (3) Since the line impedance, the line impedance can be obtained by inversion of the line admittance.

$$\bar{Z} = \frac{1}{\bar{y}_k} = \frac{1}{-j20} = j0.05$$

♦

After the discussion on how to construct the bus admittance matrix for a given system, the next section will focus on how to set up equations for solving power flow problems.

## Newton-Raphson Method and the Jacobian Matrix

In general, a nonlinear algebraic equation set may not be able to solve with a direct way. It may be only possible to be solved some numerical method. That is, it may be possible to arrange the equations so that the unknowns can be equated to a finite number of functional operations on known values. Solving the power flow problems require to use iterative techniques. The main idea in such methods is that it is possible to write a program to compute the next estimates from the current estimates. There are two methods commonly used: the Gauss-Seidel method and the Newton-Raphson method. However, only the Newton-Raphson method is discussed in this module.

As mentioned earlier, the main concern of solving power flow problems is on the complex power, or current, flowing out of the bus  $i$ . The complex transmitted power at bus  $i$  can be expressed as

$$\bar{S}_{Ti} = P_{Ti} + jQ_{Ti} = \bar{V}_i \bar{I}_{Ti}^*$$

The current can be expressed as

$$\bar{I}_{Ti} = \sum_{j=1}^n \bar{y}_{ij} \bar{V}_j, \text{ for } i = 1, 2, 3, \dots, n,$$

where

$$\bar{y}_{ij} = y_{ij} \angle \gamma_{ij},$$

and

$$\bar{V}_j = V_j \angle \delta_j.$$

Then, one can re-write the complex transmitted power at bus  $i$

$$\bar{S}_{Ti} = \sum_{j=1}^n V_i V_j y_{ij} \angle (\delta_i - \delta_j - \gamma_{ij}) = P_{Ti} + jQ_{Ti}.$$

Therefore,

$$P_{Ti} = \sum_{j=1}^n V_i V_j y_{ij} \cos(\delta_i - \delta_j - \gamma_{ij}),$$

and

$$Q_{Ti} = \sum_{j=1}^n V_i V_j y_{ij} \sin(\delta_i - \delta_j - \gamma_{ij}).$$

A general system Jacobian Matrix has the following form:

$$[J] = \begin{bmatrix} \left[ \frac{\partial P}{\partial \delta} \right] & \left[ \frac{\partial P}{\partial V} \right] \\ \left[ \frac{\partial Q}{\partial \delta} \right] & \left[ \frac{\partial Q}{\partial V} \right] \end{bmatrix}.$$

One can divide the Jacobian matrix into four quadrants, namely,

(1) Quadrant I,  $\left[ \frac{\partial P}{\partial \delta} \right]$

Since  $P_{Gi}$  and  $P_{Li}$  do not vary with the phase angles and the magnitudes of the bus voltages, the following equation can be obtained

$$\frac{\partial P_i}{\partial \delta_k} = \frac{\partial}{\partial \delta_k} [-P_{Gi} + P_{Li} + P_{Ti}] = \frac{\partial P_{Ti}}{\partial \delta_k}.$$

For the diagonal elements,  $k = i$ , the above equation can be expressed as

$$\frac{\partial P_i}{\partial \delta_i} = -\sum_{\substack{j=1 \\ j \neq i}}^n V_i V_j y_{ij} \sin(\delta_i - \delta_j - \gamma_{ij}).$$

For the off-diagonal elements,  $k \neq i$ , it can be expressed as

$$\frac{\partial P_i}{\partial \delta_k} = V_i V_k y_{ik} \sin(\delta_i - \delta_k - \gamma_{ik}), \quad i \neq k.$$

(2) Quadrant II,  $\left[ \frac{\partial P}{\partial V} \right]$

For the diagonal elements,  $k = i$ ,

$$\frac{\partial P_i}{\partial V_i} = V_i y_{ii} \cos \gamma_{ii} + \sum_{j=1}^n V_j y_{ij} \sin(\delta_i - \delta_j - \gamma_{ij}).$$

For the off-diagonal elements,  $k \neq i$ ,

$$\frac{\partial P_i}{\partial V_k} = V_i y_{ik} \cos(\delta_i - \delta_k - \gamma_{ik}), \quad i \neq k.$$

(3) Quadrant III,  $\left[ \frac{\partial Q}{\partial \delta} \right]$

Similarly, since  $Q_{Gi}$  and  $Q_{Li}$  do not vary with the phase angle and the magnitude of the bus voltages, the following equation can be obtained

$$\frac{\partial Q_i}{\partial \delta_k} = \frac{\partial}{\partial \delta_k} [-Q_{Gi} + Q_{Li} + Q_{Ti}] = \frac{\partial Q_{Ti}}{\partial \delta_k}.$$

For the diagonal elements,  $k = i$ ,

$$\frac{\partial Q_i}{\partial \delta_i} = \sum_{\substack{j=1 \\ j \neq i}}^n V_i V_j y_{ij} \cos(\delta_i - \delta_j - \gamma_{ij}).$$

For the off-diagonal elements,  $k \neq i$ ,

$$\frac{\partial Q_i}{\partial \delta_k} = -V_i V_k y_{ik} \cos(\delta_i - \delta_k - \gamma_{ik}), \quad i \neq k.$$

(4) Quadrant IV,  $\left[ \frac{\partial Q}{\partial V} \right]$

For the diagonal elements,  $k = i$ ,

$$\frac{\partial Q_i}{\partial V_i} = -V_i y_{ii} \sin \gamma_{ii} + \sum_{j=1}^n V_j y_{ij} \cos(\delta_i - \delta_j - \gamma_{ij}).$$

For the off-diagonal elements,  $k \neq i$ ,

$$\frac{\partial Q_i}{\partial V_k} = V_i y_{ik} \sin(\delta_i - \delta_k - \gamma_{ik}), \quad i \neq k.$$

Starting with the initial estimates,  $V_i^0$  and  $\delta_i^0$ , the first iteration can be expressed as follows

$$\begin{bmatrix} \Delta \delta_1^0 \\ \Delta \delta_2^0 \\ \vdots \\ \Delta \delta_n^0 \\ \Delta V_1^0 \\ \Delta V_2^0 \\ \vdots \\ \Delta V_n^0 \end{bmatrix} = - \begin{bmatrix} \frac{\partial P_1}{\partial \delta_1} & \frac{\partial P_1}{\partial \delta_2} & \dots & \frac{\partial P_1}{\partial \delta_n} & \frac{\partial P_1}{\partial V_1} & \frac{\partial P_1}{\partial V_2} & \dots & \frac{\partial P_1}{\partial V_n} \\ \frac{\partial P_2}{\partial \delta_1} & \frac{\partial P_2}{\partial \delta_2} & \dots & \frac{\partial P_2}{\partial \delta_n} & \frac{\partial P_2}{\partial V_1} & \frac{\partial P_2}{\partial V_2} & \dots & \frac{\partial P_2}{\partial V_n} \\ \vdots & \vdots & \ddots & \vdots & \vdots & \vdots & \ddots & \vdots \\ \frac{\partial P_n}{\partial \delta_1} & \frac{\partial P_n}{\partial \delta_2} & \dots & \frac{\partial P_n}{\partial \delta_n} & \frac{\partial P_n}{\partial V_1} & \frac{\partial P_n}{\partial V_2} & \dots & \frac{\partial P_n}{\partial V_n} \\ \frac{\partial Q_1}{\partial \delta_1} & \frac{\partial Q_1}{\partial \delta_2} & \dots & \frac{\partial Q_1}{\partial \delta_n} & \frac{\partial Q_1}{\partial V_1} & \frac{\partial Q_1}{\partial V_2} & \dots & \frac{\partial Q_1}{\partial V_n} \\ \frac{\partial Q_2}{\partial \delta_1} & \frac{\partial Q_2}{\partial \delta_2} & \dots & \frac{\partial Q_2}{\partial \delta_n} & \frac{\partial Q_2}{\partial V_1} & \frac{\partial Q_2}{\partial V_2} & \dots & \frac{\partial Q_2}{\partial V_n} \\ \vdots & \vdots & \ddots & \vdots & \vdots & \vdots & \ddots & \vdots \\ \frac{\partial Q_n}{\partial \delta_1} & \frac{\partial Q_n}{\partial \delta_2} & \dots & \frac{\partial Q_n}{\partial \delta_n} & \frac{\partial Q_n}{\partial V_1} & \frac{\partial Q_n}{\partial V_2} & \dots & \frac{\partial Q_n}{\partial V_n} \\ \frac{\partial \delta_1}{\partial \delta_1} & \frac{\partial \delta_1}{\partial \delta_2} & \dots & \frac{\partial \delta_1}{\partial \delta_n} & \frac{\partial \delta_1}{\partial V_1} & \frac{\partial \delta_1}{\partial V_2} & \dots & \frac{\partial \delta_1}{\partial V_n} \end{bmatrix}^{-1} \begin{bmatrix} P_1^0 \\ P_2^0 \\ \vdots \\ P_n^0 \\ Q_1^0 \\ Q_2^0 \\ \vdots \\ Q_n^0 \end{bmatrix}.$$

Then, the new estimates for next iteration can be obtained

$$\begin{bmatrix} \delta_1^1 \\ \delta_2^1 \\ \vdots \\ \delta_n^1 \\ V_1^1 \\ V_2^1 \\ \vdots \\ V_n^1 \end{bmatrix} = \begin{bmatrix} \delta_1^0 \\ \delta_2^0 \\ \vdots \\ \delta_n^0 \\ V_1^0 \\ V_2^0 \\ \vdots \\ V_n^0 \end{bmatrix} + \begin{bmatrix} \Delta\delta_1^0 \\ \Delta\delta_2^0 \\ \vdots \\ \Delta\delta_n^0 \\ \Delta V_1^0 \\ \Delta V_2^0 \\ \vdots \\ \Delta V_n^0 \end{bmatrix}.$$

For the  $m$ th iteration,

$$\begin{bmatrix} \Delta\tilde{\delta}^{m-1} \\ \Delta\tilde{V}^{m-1} \end{bmatrix} = -[J^m]^{-1} \begin{bmatrix} \tilde{P}^m \\ \tilde{Q}^m \end{bmatrix},$$

and

$$\delta_i^m = \delta_i^{m-1} + \Delta\delta_i^{m-1},$$

$$V_i^m = V_i^{m-1} + \Delta V_i^{m-1}.$$

One needs to continue the iterative process until some predetermined tolerances been reached, i.e.,  $\Delta\delta_i^{m-1} < 10^{-6}$  and  $\Delta V_i^{m-1} < 10^{-6}$ .

Example 5-5: A 3-bus system, as shown in Figure 5-6, has two generators and one load. The parameters and models for the transmission lines are assumed to be the same as given in Example 5-2. If bus 1 is chosen as the swing bus with 1.0 pu voltage and zero degree. The scheduled voltage at bus 2 is 1.05 pu. Find  $\delta_2$ ,  $\delta_3$ ,  $V_3$ ,  $P_{G1}$ ,  $Q_{G1}$  and  $Q_{G2}$ .

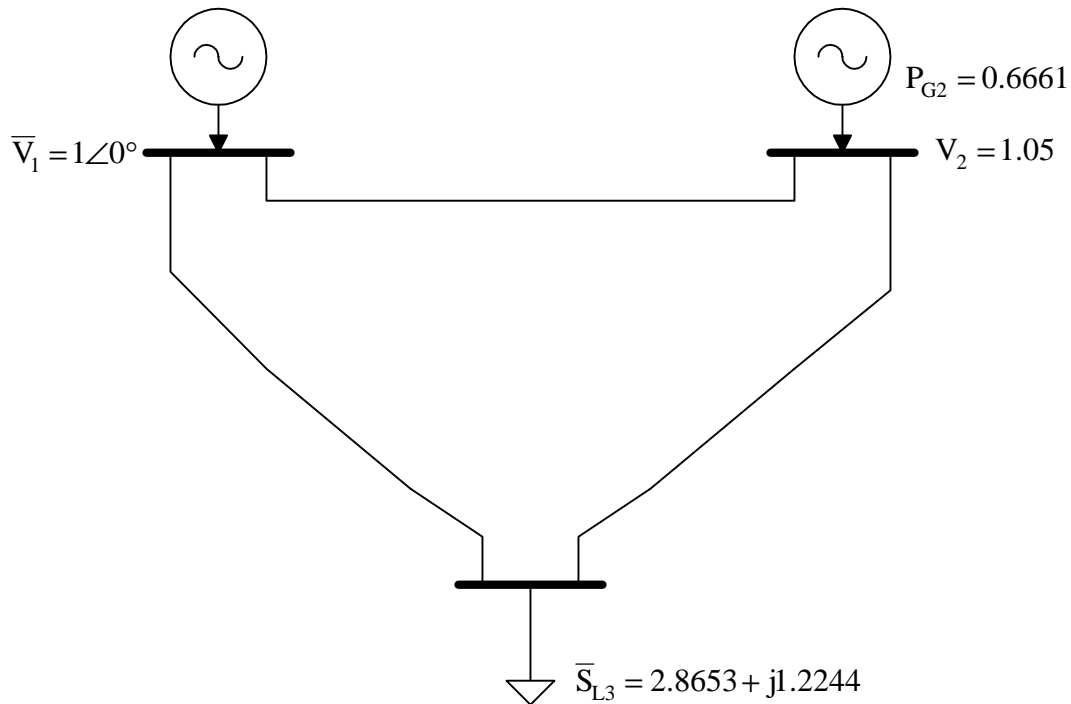

Fig. 5-6. 3-bus system with two generators and one load.

Solution:

Since the series resistance of the transmission lines is neglected, the bus admittance matrix obtained in Example 5-2 can be re-written as

$$[\tilde{Y}] = j \begin{bmatrix} -19.98 & 10 & 10 \\ 10 & -19.98 & 10 \\ 10 & 10 & -19.98 \end{bmatrix} = j \begin{bmatrix} b_{11} & b_{12} & b_{13} \\ b_{21} & b_{22} & b_{23} \\ b_{31} & b_{32} & b_{33} \end{bmatrix}$$

The active transmitted power can be simplified as

$$P_{Ti} = \sum_{j=1}^n V_i V_j y_{ij} \cos(\delta_i - \delta_j - \gamma_{ij}) = \sum_{j=1}^n V_i V_j b_{ij} \sin(\delta_i - \delta_j)$$

The bus 1 is the swing bus, therefore, there is no need to find  $\delta_1$  and  $V_1$  (both are given).

The active transmitted power at bus 2 and bus 3 are needed and can be obtained as

$$\begin{aligned} P_{T2} &= V_2 V_1 b_{21} \sin(\delta_2 - \delta_1) + V_2 V_2 b_{22} \sin(\delta_2 - \delta_2) + V_2 V_3 b_{23} \sin(\delta_2 - \delta_3) \\ &= 10.5 \sin(\delta_2) + 10.5 \sin(\delta_2 - \delta_3) \end{aligned}$$

$$\begin{aligned} P_{T3} &= V_3 V_1 b_{31} \sin(\delta_3 - \delta_1) + V_3 V_2 b_{32} \sin(\delta_3 - \delta_2) + V_3 V_3 b_{33} \sin(\delta_3 - \delta_3) \\ &= 10V_3 \sin(\delta_3) + 10.5V_3 \sin(\delta_3 - \delta_2) \end{aligned}$$

Similarly, the reactive transmitted power can be simplified as

$$Q_{Ti} = \sum_{j=1}^n V_i V_j y_{ij} \sin(\delta_i - \delta_j - \gamma_{ij}) = -\sum_{j=1}^n V_i V_j b_{ij} \cos(\delta_i - \delta_j)$$

Because the voltage magnitude at bus 2 is known already, the equation involving  $Q_2$  can be eliminated. The reactive transmitted power at bus 3 can be obtained as follows

$$\begin{aligned} Q_{T3} &= -[V_3 V_1 b_{31} \cos(\delta_3 - \delta_1) + V_3 V_2 b_{32} \cos(\delta_3 - \delta_2) + V_3 V_3 b_{33} \cos(\delta_3 - \delta_3)] \\ &= -[10 \cos(\delta_3) + 10.5 V_3 \cos(\delta_3 - \delta_2) - 19.98 V_3^2] \end{aligned}$$

The system Jacobian Matrix can be expressed as

$$[J] = \begin{bmatrix} \frac{\partial P_2}{\partial \delta_2} & \frac{\partial P_2}{\partial \delta_3} & \frac{\partial P_2}{\partial V_3} \\ \frac{\partial P_3}{\partial \delta_2} & \frac{\partial P_3}{\partial \delta_3} & \frac{\partial P_3}{\partial V_3} \\ \frac{\partial Q_3}{\partial \delta_2} & \frac{\partial Q_3}{\partial \delta_3} & \frac{\partial Q_3}{\partial V_3} \end{bmatrix},$$

where

$$\frac{\partial P_2}{\partial \delta_2} = \frac{\partial P_{T2}}{\partial \delta_2} = 10.5 \cos(\delta_2) + 10.5 V_3 \cos(\delta_2 - \delta_3),$$

$$\frac{\partial P_2}{\partial \delta_3} = \frac{\partial P_{T2}}{\partial \delta_3} = -10.5 V_3 \cos(\delta_2 - \delta_3),$$

$$\frac{\partial P_2}{\partial V_3} = \frac{\partial P_{T2}}{\partial V_3} = 10.5 \sin(\delta_2 - \delta_3),$$

$$\frac{\partial P_3}{\partial \delta_2} = \frac{\partial P_{T3}}{\partial \delta_2} = -10.5 V_3 \cos(\delta_3 - \delta_2),$$

$$\frac{\partial P_3}{\partial \delta_3} = \frac{\partial P_{T3}}{\partial \delta_3} = 10 \cos(\delta_3) + 10.5 V_3 \cos(\delta_3 - \delta_2),$$

$$\frac{\partial P_3}{\partial V_3} = \frac{\partial P_{T3}}{\partial V_3} = 10 \sin(\delta_3) + 10.5 \sin(\delta_3 - \delta_2),$$

$$\frac{\partial Q_3}{\partial \delta_2} = \frac{\partial Q_{T3}}{\partial \delta_2} = -10.5 V_3 \sin(\delta_3 - \delta_2),$$

$$\frac{\partial Q_3}{\partial \delta_3} = \frac{\partial Q_{T3}}{\partial \delta_3} = 10 V_3 \sin(\delta_3) + 10.5 V_3 \sin(\delta_3 - \delta_2),$$

and

$$\frac{\partial Q_3}{\partial V_3} = \frac{\partial Q_{T3}}{\partial V_3} = -[10 \cos(\delta_3) + 10.5 \cos(\delta_3 - \delta_2) - 39.96 V_3].$$

With all the above equations, one should be able to start the iterative process. To start, one needs to select the initial estimates, for instance, a “flat start” meaning all voltage angles to be zero and all voltage magnitudes to be one.

*1<sup>st</sup> iteration:*

A flat start is selected,  $\delta_2^0 = 0$ ,  $\delta_3^0 = 0$  and  $V_3^0 = 1$ . With the initial estimates, the system Jacobian matrix with numerical values can be obtained

$$[J^1] = \begin{bmatrix} 21 & -10.5 & 0 \\ -10.5 & 20.5 & 0 \\ 0 & 0 & 19.46 \end{bmatrix}$$

The inverse of the system Jacobian matrix

$$[J^1]^{-1} = \begin{bmatrix} 0.064 & 0.0328 & 0 \\ 0.0328 & 0.0656 & 0 \\ 0 & 0 & 0.0514 \end{bmatrix}$$

The equations for the active power and reactive power

$$P_i = -P_{Gi} + P_{Li} + P_{Ti}$$

$$Q_i = -Q_{Gi} + Q_{Li} + Q_{Ti}$$

The active and reactive power at buses 2 and 3 for the iteration

$$P_2^1 = -P_{G2} + 0 + P_{T2}^1 = -0.6661 + 0 = -0.6661$$

$$P_3^1 = -0 + P_{L3} + P_{T3}^1 = 2.8653 + 0 = 2.8653$$

$$Q_3^1 = -0 + Q_{L3} + Q_{T3}^1 = 1.2244 - 0.52 = 0.7044$$

Therefore,

$$\begin{bmatrix} \Delta\delta_2^1 \\ \Delta\delta_3^1 \\ \Delta V_3^2 \end{bmatrix} = -[J^1]^{-1} \begin{bmatrix} P_2^1 \\ P_3^1 \\ Q_3^1 \end{bmatrix} = - \begin{bmatrix} 0.064 & 0.0328 & 0 \\ 0.0328 & 0.0656 & 0 \\ 0 & 0 & 0.0514 \end{bmatrix} \begin{bmatrix} -0.6661 \\ 2.8653 \\ 0.7044 \end{bmatrix} = \begin{bmatrix} -0.0513\text{rad} \\ -0.166\text{rad} \\ -0.0362\text{pu} \end{bmatrix} = \begin{bmatrix} -2.9393^\circ \\ -9.5111^\circ \\ -0.0362\text{pu} \end{bmatrix}$$

The new estimates for next iteration

$$\delta_2^1 = \delta_2^0 + \Delta\delta_2^1 = 0 + (-2.9393^\circ) = -2.9393^\circ$$

$$\delta_3^1 = \delta_3^0 + \Delta\delta_3^1 = 0 + (-9.5111^\circ) = -9.5111^\circ$$

$$V_3^1 = V_3^0 + \Delta V_3^1 = 1 + (-0.0362) = 0.9638\text{pu}$$

*2<sup>nd</sup> iteration:*

$$[J^2] = \begin{bmatrix} 20.5396 & -10.0534 & 1.2017 \\ -10.0534 & 19.5589 & -2.8541 \\ 1.1583 & -2.7508 & 18.2199 \end{bmatrix}$$

$$[J^2]^{-1} = \begin{bmatrix} 0.0651 & 0.0336 & 0.001 \\ 0.0336 & 0.0696 & 0.0087 \\ 0.0009 & 0.0084 & 0.0561 \end{bmatrix}$$

$$P_2^2 = -P_{G2} + 0 + P_{T2}^2 = -0.6661 + 0.6198 = -0.0463$$

$$P_3^2 = -0 + P_{L3} + P_{T3}^2 = 2.8653 - 2.7508 = 0.1145$$

$$Q_3^2 = -0 + Q_{L3} + Q_{T3}^2 = 1.2244 - 0.9993 = 0.2251$$

$$\begin{bmatrix} \Delta\delta_2^2 \\ \Delta\delta_3^2 \\ \Delta V_3^2 \end{bmatrix} = - \begin{bmatrix} 0.0651 & 0.0336 & 0.001 \\ 0.0336 & 0.0696 & 0.0087 \\ 0.0009 & 0.0084 & 0.0561 \end{bmatrix} \begin{bmatrix} -0.0463 \\ 0.1145 \\ 0.2251 \end{bmatrix} = \begin{bmatrix} -0.00106\text{rad} \\ -0.008372\text{rad} \\ -0.01355\text{pu} \end{bmatrix} = \begin{bmatrix} -0.0606^\circ \\ -0.4797^\circ \\ -0.01355\text{pu} \end{bmatrix}$$

The new estimates for next iteration

$$\delta_2^2 = \delta_2^1 + \Delta\delta_2^2 = -2.9393^\circ - 0.0606^\circ = -2.9999^\circ$$

$$\delta_3^2 = \delta_3^1 + \Delta\delta_3^2 = -9.5111^\circ - 0.4797^\circ = -9.9908^\circ$$

$$V_3^2 = V_3^1 + \Delta V_3^2 = 0.9638 + (-0.01355) = 0.95025\text{pu}$$

3<sup>rd</sup> iteration:

$$[J^2] = \begin{bmatrix} 20.5396 & -10.0534 & 1.2017 \\ -10.0534 & 19.5589 & -2.8541 \\ 1.1583 & -2.7508 & 18.2199 \end{bmatrix}$$

$$[J^2]^{-1} = \begin{bmatrix} 0.0651 & 0.0336 & 0.001 \\ 0.0336 & 0.0696 & 0.0087 \\ 0.0009 & 0.0084 & 0.0561 \end{bmatrix}$$

$$P_2^2 = -P_{G2} + 0 + P_{T2}^2 = -0.6661 + 0.6198 = -0.0463$$

$$P_3^2 = -0 + P_{L3} + P_{T3}^2 = 2.8653 - 2.7508 = 0.1145$$

$$Q_3^2 = -0 + Q_{L3} + Q_{T3}^2 = 1.2244 - 0.9993 = 0.2251$$

$$\begin{bmatrix} \Delta\delta_2^2 \\ \Delta\delta_3^2 \\ \Delta V_3^2 \end{bmatrix} = - \begin{bmatrix} 0.0651 & 0.0336 & 0.001 \\ 0.0336 & 0.0696 & 0.0087 \\ 0.0009 & 0.0084 & 0.0561 \end{bmatrix} \begin{bmatrix} -0.0463 \\ 0.1145 \\ 0.2251 \end{bmatrix} = \begin{bmatrix} -0.00106\text{rad} \\ -0.008372\text{rad} \\ -0.01355\text{pu} \end{bmatrix} = \begin{bmatrix} -0.0606^\circ \\ -0.4797^\circ \\ -0.01355\text{pu} \end{bmatrix}$$

The new estimates for next iteration

$$\delta_2^2 = \delta_2^1 + \Delta\delta_2^2 = -2.9393^\circ - 0.0606^\circ = 2.9999^\circ$$

$$\delta_3^2 = \delta_3^1 + \Delta\delta_3^2 = -9.5111^\circ - 0.4797^\circ = -9.9908^\circ$$

$$V_3^2 = V_3^1 + \Delta V_3^2 = 0.9638 + (-0.01355) = 0.95025\text{pu}$$

If one performs one more iteration, the following may be obtained,

$$\delta_2^3 = 2.9997^\circ$$

$$\delta_3^3 = -9.9993^\circ$$

$$V_3^3 = 0.95\text{pu}$$

Since these values are very close to the values from the previous iteration, one may stop the iterative process. Therefore,

$$\delta_2 = 2.9997^\circ$$

$$\delta_3 = -9.9993^\circ$$

$$V_3 = 0.95\text{pu}$$

To find  $P_{G1}$ ,  $Q_{G1}$  and  $Q_{G2}$ , one needs to use the final values obtained on voltage angles and magnitudes.

$$P_{G1} = P_{L1} + P_{T1} = 0 + P_{T1} = V_1 V_2 b_{12} \sin(-\delta_2) + V_1 V_3 b_{13} \sin(-\delta_3) = 2.199$$

$$Q_{G1} = Q_{L1} + Q_{T1} = 0 + Q_{T1} = -[V_1 V_1 b_{11} + V_1 V_2 b_{12} \cos(-\delta_2) + V_1 V_3 b_{13} \cos(-\delta_3)] = 0.1387$$

$$Q_{G2} = Q_{L2} + Q_{T2} = 0 + Q_{T2} = -[V_2 V_1 b_{21} \cos(\delta_2 - \delta_1) + V_2 V_2 b_{22} + V_2 V_3 b_{23} \cos(\delta_2 - \delta_3)] \\ = -1.6395$$

◆

There is another important parameter for transmission planners to know, namely, the line flows. After the bus voltage magnitudes and phase angles are obtained, one can calculate the line flows, both active and reactive power, to see the loading conditions of the transmission lines. To do that, one may recall the transmission line model between buses  $i$  and  $j$ , as shown in Figure 5-7. The complex transmitted power flowing from bus  $i$  to bus  $j$  measured at bus  $i$  can be calculated as

$$\bar{S}_{ij} = \bar{V}_i \bar{I}_i^* = \bar{V}_i \left[ \frac{\bar{Y}}{2} \bar{V}_i + \frac{\bar{V}_i - \bar{V}_j}{\bar{Z}} \right]^*$$

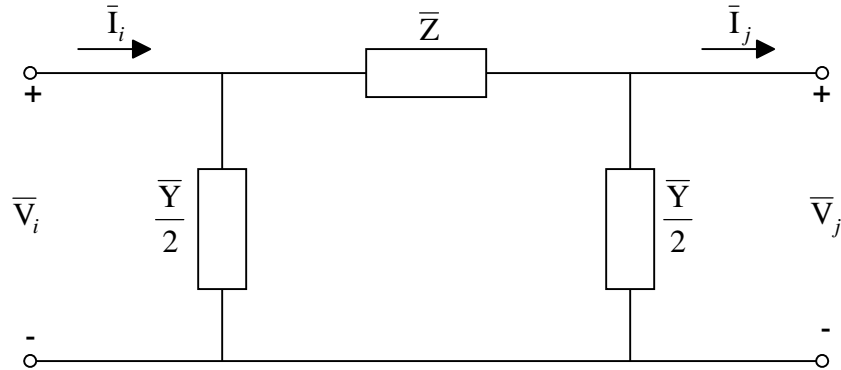

Fig. 5-7. Transmission line model between buses *i* and *j*.

Example 5-6: A 3-bus system, as shown in Figure 5-8, has two generators and one loads. The transmissions are represented with only their series impedance as labeled in the figure. Find the  $\delta_2$ ,  $\delta_3$ ,  $V_2$ ,  $P_{G1}$ ,  $Q_{G1}$ ,  $Q_{G3}$  and line flows  $\bar{S}_{12}$  and  $\bar{S}_{21}$ .

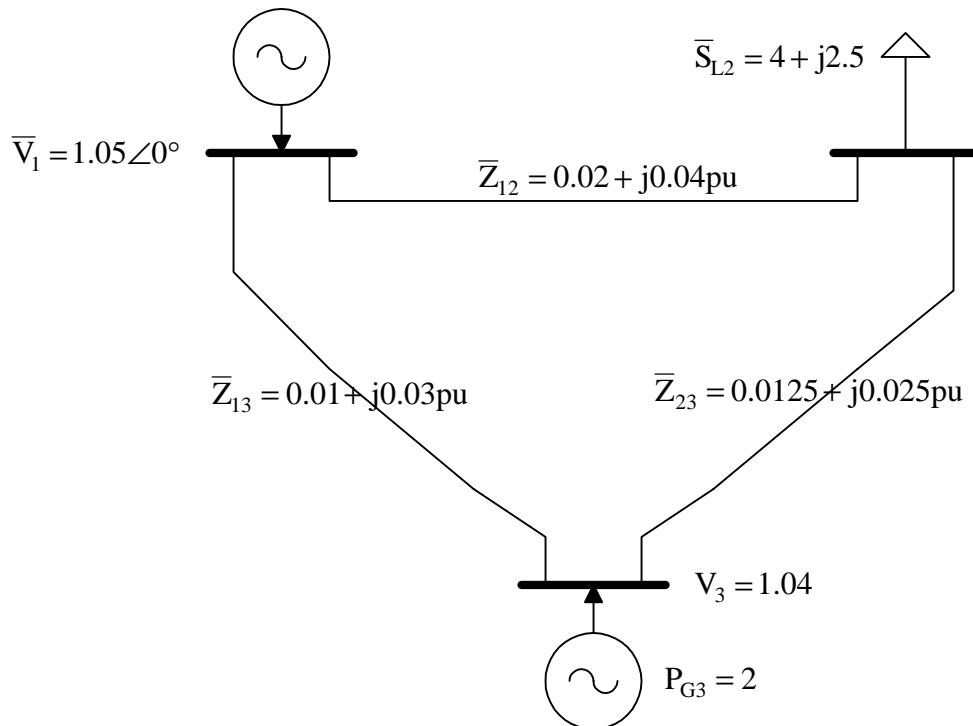

Fig. 5-8. 3-bus system for Example 5-6.

Solution:

Before constructing the bus admittance, one should first obtain the line admittances.

The line admittance between buses 1 and 2:

$$\bar{y} = \frac{1}{\bar{Z}_{12}} = 10 - j20$$

The line admittance between buses 1 and 3:

$$\bar{y} = \frac{1}{\bar{Z}_{13}} = 10 - j30$$

The line admittance between buses 2 and 3:

$$\bar{y} = \frac{1}{\bar{Z}_{23}} = 16 - j32$$

The bus admittance matrix can be obtained as follows:

$$[\tilde{Y}] = \begin{bmatrix} 20 - j50 & -10 + j20 & -10 + j30 \\ -10 + j20 & 26 - j52 & -16 + j32 \\ -10 + j30 & -16 + j32 & 26 - j62 \end{bmatrix} = \begin{bmatrix} 53.85 \angle -68.2^\circ & 22.36 \angle 116.6^\circ & 31.62 \angle 108.4^\circ \\ 22.36 \angle 116.6^\circ & 58.14 \angle -63.4^\circ & 35.78 \angle 116.6^\circ \\ 31.62 \angle 108.4^\circ & 35.78 \angle 116.6^\circ & 67.23 \angle -67.2^\circ \end{bmatrix}$$

*1<sup>st</sup> iteration:*

With a flat start,  $\delta_2^0 = 0$ ,  $\delta_3^0 = 0$  and  $V_2^0 = 1$ , as the initial estimates, the system Jacobian matrix with numerical values can be obtained

$$[J^1] = \begin{bmatrix} 54.265505 & -33.272552 & 24.891259 \\ -33.272552 & 66.036292 & -16.661653 \\ -27.174141 & 16.661653 & 49.706749 \end{bmatrix}$$

The inverse of the system Jacobian matrix

$$[J^1]^{-1} = \begin{bmatrix} 0.0231228 & 0.0134357 & -0.0070754 \\ 0.0136827 & 0.0219128 & 0.0004933 \\ 0.0080546 & 0 & 0.0160846 \end{bmatrix}$$

Then,

$$\begin{bmatrix} \Delta\delta_2^1 \\ \Delta\delta_3^1 \\ \Delta V_2^1 \end{bmatrix} = - \begin{bmatrix} 0.0231228 & 0.0134357 & -0.0070754 \\ 0.0136827 & 0.0219128 & 0.0004933 \\ 0.0080546 & 0 & 0.0160846 \end{bmatrix} \begin{bmatrix} 2.8585725 \\ -1.3821402 \\ 0.220622 \end{bmatrix} = \begin{bmatrix} -0.0459671 \text{ rad} \\ -0.008935 \text{ rad} \\ -0.0265732 \text{ pu} \end{bmatrix}$$

Convert the radians to degrees, one can obtain the new estimates for next iteration

$$\delta_2^1 = \delta_2^0 + \Delta\delta_2^1 = 0 + (-2.63^\circ) = -2.63^\circ$$

$$\delta_3^1 = \delta_3^0 + \Delta\delta_3^1 = 0 + (-0.512^\circ) = -0.512^\circ$$

$$V_2^1 = V_2^0 + \Delta V_2^1 = 1 + (-0.0265732) = 0.9734267 \text{ pu}$$

If one performs one more iteration, the followings may be obtained

$$\delta_2^2 = \delta_2^1 + \Delta \delta_2^2 = -2.63^\circ - 0.066^\circ = -2.696^\circ$$

$$\delta_3^2 = \delta_3^1 + \Delta \delta_3^2 = -0.512^\circ + 0.0132^\circ = -0.4988^\circ$$

$$V_3^2 = V_3^1 + \Delta V_3^2 = 0.9734267 + (-0.0017467) = 0.97168 \text{ pu}$$

One may use these values to calculate  $P_{G1}$ ,  $Q_{G1}$ ,  $Q_{G3}$  and line flows  $\bar{S}_{12}$  and  $\bar{S}_{21}$ .

$$P_{G1} = P_{L1} + P_{T1} = 0 + 2.1905591 = 2.1905591 \text{ pu}$$

$$Q_{G1} = Q_{L1} + Q_{T1} = 0 + 1.410112 = 1.410112 \text{ pu}$$

$$Q_{G3} = Q_{L3} + Q_{T3} = 0 + 1.4391429 = 1.4391429 \text{ pu}$$

$$\begin{aligned} \bar{S}_{12} &= \bar{V}_1 \bar{I}_{12}^* = \bar{V}_1 \left[ \frac{\bar{V}_1 - \bar{V}_2}{\bar{Z}_{12}} \right]^* = (1.05 \angle 0^\circ) \left[ \frac{1.05 - 0.97168 \angle -2.696^\circ}{0.0447213 \angle 63.4^\circ} \right]^* \\ &= 1.794232 + j1.1862256 \end{aligned}$$

$$\begin{aligned} \bar{S}_{21} &= \bar{V}_2 \bar{I}_{21}^* = \bar{V}_2 \left[ \frac{\bar{V}_2 - \bar{V}_1}{\bar{Z}_{12}} \right]^* = (0.97168 \angle -2.696^\circ) \left[ \frac{0.97168 \angle (-2.696^\circ) - 1.05}{0.0447213 \angle 63.4^\circ} \right]^* \\ &= -1.7112613 - j1.0166383 \end{aligned}$$

◆

Please notice that a negative line flow indicates the transmitted power is flowing into the bus while a positive line flow indicates the transmitted power is flowing out of the bus as defined in Figure 5-2. For instance, the active power flow is flowing from bus 1 to bus 2. At its sending end (bus 1), the active power is 1.794232pu while only 1.7112613pu of active power is received at the receiving end (bus 2). The difference between these two numbers is the active power loss of the line between buses 1 and 2.