

Power Systems - Basic Concepts and Applications

Part II

By Shih-Min Hsu, Ph.D., P.E.

MODULE 4: Symmetrical Components and its Applications.

Overview

This module discusses an important mathematical tool for unbalanced fault calculations, namely, the symmetrical components. The deviations of four common types of faults are presented. Examples on short circuit calculations on various types of faults are given to illustrate some practical applications.

Symmetrical Components

Although power systems are designed and normally operated in balanced (symmetrical) three-phase sinusoidal conditions, there are certain situations that can cause undesired conditions, namely, the unbalanced conditions. Under normal steady-state conditions, the calculations for a balanced three-phase system can be performed using the per phase analysis. For instance, a per phase system for Phase “a” can be used to do all the calculations, then, the numerical quantities for Phases “b” and “c” can be obtained by shifting the phase angles by 120° (minus 120° for Phase “b”, and plus 120° for Phase “c”). However, for unbalanced conditions, such a method can not be applied. Instead, symmetrical components can be used.

As mentioned in Part I, in power systems the voltage sources generated by generators have a positive sequence, or a-b-c sequence. The phase voltages of a balanced three-phase system with a positive sequence are shown in Figure 4-1. Consequently, under normal balanced operations, the currents in such systems have a positive sequence as well. In a positive sequence, the Phase “b” quantities lags the Phase “a” quantities by 120° , while the Phase “c” quantities leads the Phase “a” quantities by 120° . Therefore, they form a balanced three-phase system. It is a common practice to add a “1” in the subscript to clearly indicate positive sequence quantities.

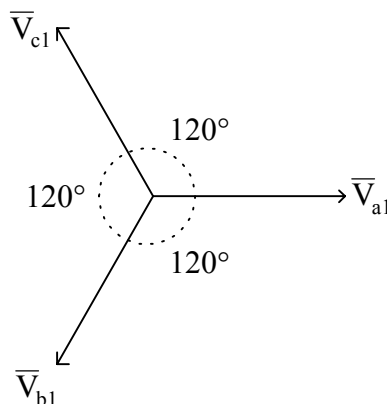

Fig. 4-1. A balanced three-phase voltage source with a positive (a-b-c) sequence.

The opposite of the positive sequence is the negative sequence, or a-c-b sequence. In a negative sequence, the Phase “b” quantities leads the Phase “a” quantities by 120° , while the Phase “c” quantities lags the phase “a” quantities by 120° . Their relationship is shown in Figure 4-2. Since they are 120° apart, they also form a balanced three-phase system. A “2” is added to indicate negative sequence quantities.

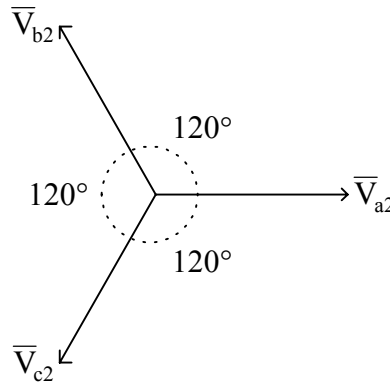

Fig. 4-2. A balanced three-phase voltage source with a negative (a-c-b) sequence.

Any unbalanced three-phase quantities can be decomposed into three components, positive sequence, negative sequence, and zero sequence. Unlike the positive and negative sequences, the three quantities in a zero sequence set are not balanced. They are equal in magnitude, and they are in phase, as shown in Figure 4-3. Similar to positive and negative sequence quantities, a “0” is added for zero sequence components.

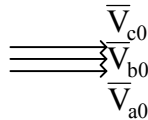

Fig. 4-3. A set of zero sequence quantities.

After the introduction of the positive, negative and zero sequence components, any three-phase quantities, balanced or unbalanced, can be expressed in terms of these components, for instance, for phase voltages,

$$\bar{V}_a = \bar{V}_{a0} + \bar{V}_{a1} + \bar{V}_{a2},$$

$$\bar{V}_b = \bar{V}_{b0} + \bar{V}_{b1} + \bar{V}_{b2},$$

and

$$\bar{V}_c = \bar{V}_{c0} + \bar{V}_{c1} + \bar{V}_{c2},$$

where

\bar{V}_{a0} , \bar{V}_{b0} , and \bar{V}_{c0} are the zero sequence quantities for Phases a, b and c, respectively,

\bar{V}_{a1} , \bar{V}_{b1} , and \bar{V}_{c1} are the positive sequence quantities for Phases a, b and c, respectively,

\bar{V}_{a2} , \bar{V}_{b2} , and \bar{V}_{c2} are the negative sequence quantities for Phases a, b and c, respectively.

A so called “ a ” operator is commonly used in symmetrical component representation. It is defined as a vector having 1 as its magnitude and 120° as its phase angle, namely,

$$a = 1\angle 120^\circ.$$

Therefore,

$$a^2 = a \times a = (1\angle 120^\circ)(1\angle 120^\circ) = 1\angle 240^\circ = 1\angle -120^\circ,$$

and

$$a^3 = a^2 \times a = (1\angle 240^\circ)(1\angle 120^\circ) = 1\angle 360^\circ = 1.$$

Clearly, the sum of them equals zero. Figure 4-4 shows a graphical representation of this fact.

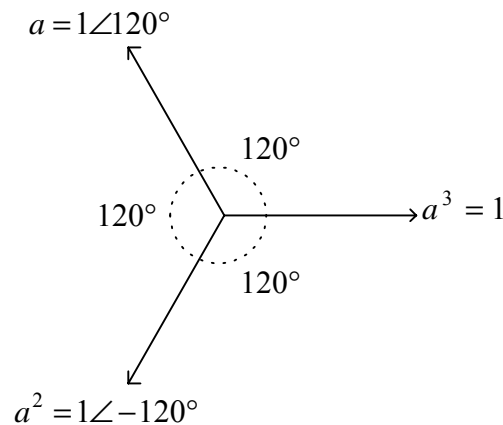

Fig. 4-4. Definition of a operator.

The previously discussed phase voltages \bar{V}_b and \bar{V}_c can be expressed in terms of \bar{V}_{a0} , \bar{V}_{a1} and \bar{V}_{a2} , namely,

$$\bar{V}_b = \bar{V}_{a0} + a^2\bar{V}_{a1} + a\bar{V}_{a2},$$

and

$$\bar{V}_c = \bar{V}_{a0} + a\bar{V}_{a1} + a^2\bar{V}_{a2}.$$

Then, the three phase voltages can be re-written in a matrix notation,

$$\begin{bmatrix} \bar{V}_a \\ \bar{V}_b \\ \bar{V}_c \end{bmatrix} = \begin{bmatrix} 1 & 1 & 1 \\ 1 & a^2 & a \\ 1 & a & a^2 \end{bmatrix} \begin{bmatrix} \bar{V}_{a0} \\ \bar{V}_{a1} \\ \bar{V}_{a2} \end{bmatrix} = [T] \begin{bmatrix} \bar{V}_{a0} \\ \bar{V}_{a1} \\ \bar{V}_{a2} \end{bmatrix},$$

where

$$[T] = \begin{bmatrix} 1 & 1 & 1 \\ 1 & a^2 & a \\ 1 & a & a^2 \end{bmatrix}.$$

Some convention neglects the subscript “a” in the zero sequence, positive sequence and negative sequence components and expresses them as \bar{V}_0 , \bar{V}_1 and \bar{V}_2 , respectively.

On the other hand, if the sequence quantities are given, the phase quantities can be obtained by

$$\begin{bmatrix} \bar{V}_0 \\ \bar{V}_1 \\ \bar{V}_2 \end{bmatrix} = [T]^{-1} \begin{bmatrix} \bar{V}_a \\ \bar{V}_b \\ \bar{V}_c \end{bmatrix} = \frac{1}{3} \begin{bmatrix} 1 & 1 & 1 \\ 1 & a & a^2 \\ 1 & a^2 & a \end{bmatrix} \begin{bmatrix} \bar{V}_a \\ \bar{V}_b \\ \bar{V}_c \end{bmatrix}.$$

If all of these quantities are for currents, then

$$\begin{bmatrix} \bar{I}_a \\ \bar{I}_b \\ \bar{I}_c \end{bmatrix} = [T] \begin{bmatrix} \bar{I}_0 \\ \bar{I}_1 \\ \bar{I}_2 \end{bmatrix}, \text{ (or } [\tilde{I}_{abc}] = [T][\tilde{I}_{012}])$$

and

$$\begin{bmatrix} \bar{I}_0 \\ \bar{I}_1 \\ \bar{I}_2 \end{bmatrix} = [T]^{-1} \begin{bmatrix} \bar{I}_a \\ \bar{I}_b \\ \bar{I}_c \end{bmatrix}. \text{ (or } [\tilde{I}_{012}] = [T]^{-1}[\tilde{I}_{abc}])$$

Example 4-1: Given that, $\bar{V}_{a1} = 1\angle 0^\circ$, $\bar{V}_{a2} = 2\angle 60^\circ$ and $\bar{V}_{a0} = 1\angle 120^\circ$,

- Draw a phasor diagram for each sequence (positive, negative and zero) showing its three symmetrical components.
- Graphically add the appropriate phasors to obtain the phase voltages \bar{V}_a , \bar{V}_b and \bar{V}_c .
- Evaluate $[\tilde{V}_{abc}]$, using $[T][\tilde{V}_{012}]$.

Solution:

- With the three sequence quantities given, the phasor diagram for positive, negative and zero sequence components can be obtained and are shown in Figure 4-5 (i), (ii) and (iii), respectively.

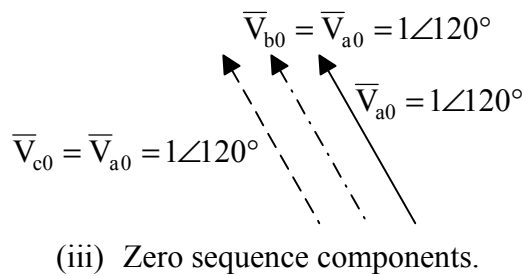
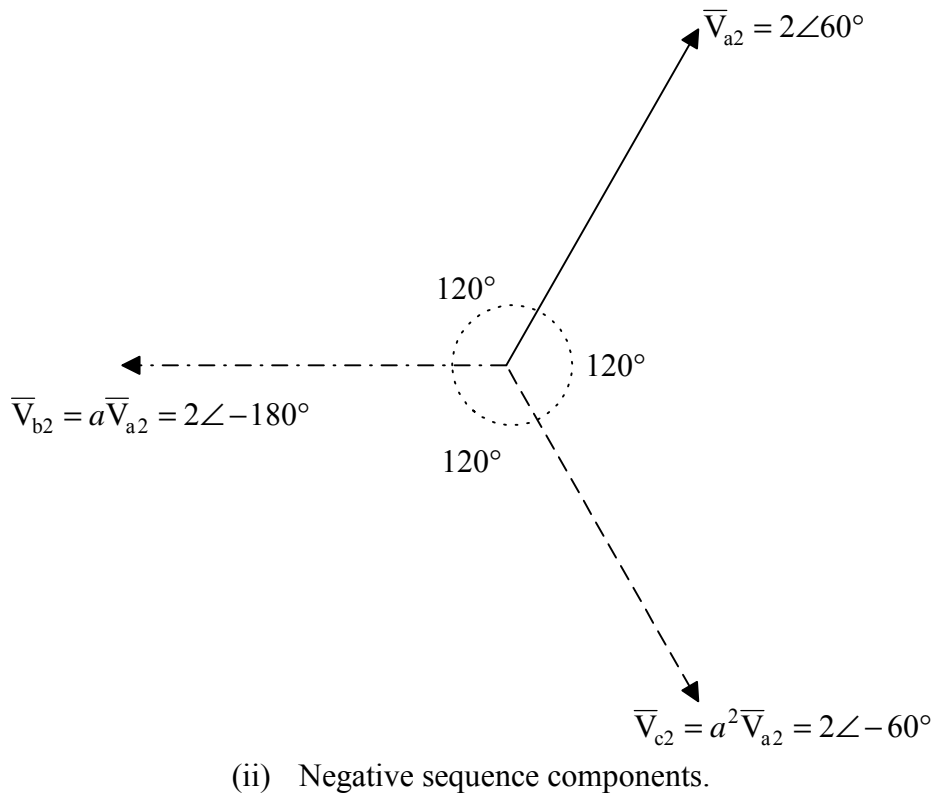
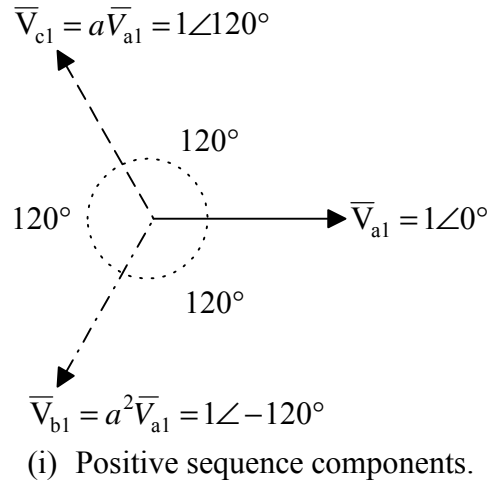

Fig. 4-5. (i) Positive, (ii) negative and (iii) zero sequence diagrams.

(b) The phase voltages can be obtained by graphically adding their corresponding sequence components as shown in Figure 4-6. For instance, $\bar{V}_a = \bar{V}_{a1} + \bar{V}_{a2} + \bar{V}_{a0}$. Please note that \bar{V}_c is located at the origin (0).

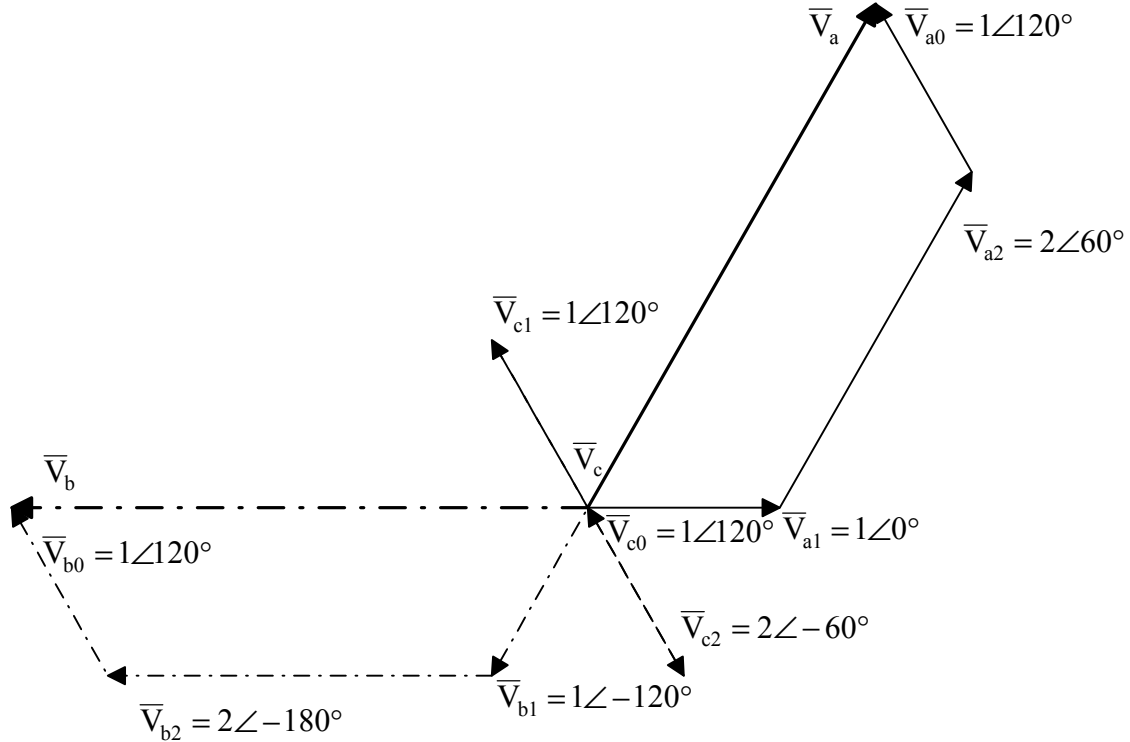

Fig. 4-6. Phase voltages graphically obtained by adding their corresponding sequence components.

(c)

$$\begin{bmatrix} \bar{V}_a \\ \bar{V}_b \\ \bar{V}_c \end{bmatrix} = \begin{bmatrix} 1 & 1 & 1 \\ 1 & a^2 & a \\ 1 & a & a^2 \end{bmatrix} \begin{bmatrix} 1\angle 120^\circ \\ 1\angle 0^\circ \\ 2\angle 60^\circ \end{bmatrix} = \begin{bmatrix} 1 & 1 & 1 \\ 1 & 1\angle -120^\circ & 1\angle 120^\circ \\ 1 & 1\angle 120^\circ & 1\angle -120^\circ \end{bmatrix} \begin{bmatrix} 1\angle 120^\circ \\ 1\angle 0^\circ \\ 2\angle 60^\circ \end{bmatrix} = \begin{bmatrix} 3\angle 60^\circ \\ 3\angle 180^\circ \\ 0 \end{bmatrix}$$

which match the phase voltages obtained in Part (b). ◆

Example 4-2: If the unbalanced phase voltages of the three-phase system are given as

$$\begin{bmatrix} \bar{V}_a \\ \bar{V}_b \\ \bar{V}_c \end{bmatrix} = \begin{bmatrix} 3\angle 60^\circ \\ 3\angle 180^\circ \\ 0 \end{bmatrix},$$

find the corresponding symmetrical components?

Solution:

$$\begin{bmatrix} \bar{V}_{a0} \\ \bar{V}_{a1} \\ \bar{V}_{a2} \end{bmatrix} = [T]^{-1} \begin{bmatrix} \bar{V}_a \\ \bar{V}_b \\ \bar{V}_c \end{bmatrix} = \frac{1}{3} \begin{bmatrix} 1 & 1 & 1 \\ 1 & 1\angle 120^\circ & 1\angle -120^\circ \\ 1 & 1\angle -120^\circ & 1\angle 120^\circ \end{bmatrix} \begin{bmatrix} 3\angle 60^\circ \\ 3\angle 180^\circ \\ 0 \end{bmatrix} = \begin{bmatrix} 1\angle 120^\circ \\ 1 \\ 2\angle 60^\circ \end{bmatrix}$$

◆

Sequence Networks

One of the most useful concepts about the symmetrical components is the sequence network. A sequence network is an equivalent network for power system under the assumption that only one sequence component of voltages and currents is presented in the system. There will be no interaction between each sequence network and each of them is independent of each other. The positive sequence network is the only one containing voltage source since generators produce only voltages of positive sequence. Negative and zero sequence networks contain only their corresponding impedances and these impedances are obtained based on the location of the fault under investigation. These sequence networks are shown in Figure 4-7. The types of fault conditions will determine the connections between the sequence networks. The positive sequence impedance, \bar{Z}_1 , is the impedance looking into the positive sequence network from the fault point. Similarly, the negative sequence impedance, \bar{Z}_2 , is the impedance looking into the negative sequence network from the fault point, and the zero sequence impedance, \bar{Z}_0 , is the impedance looking into the zero sequence network from the fault point.

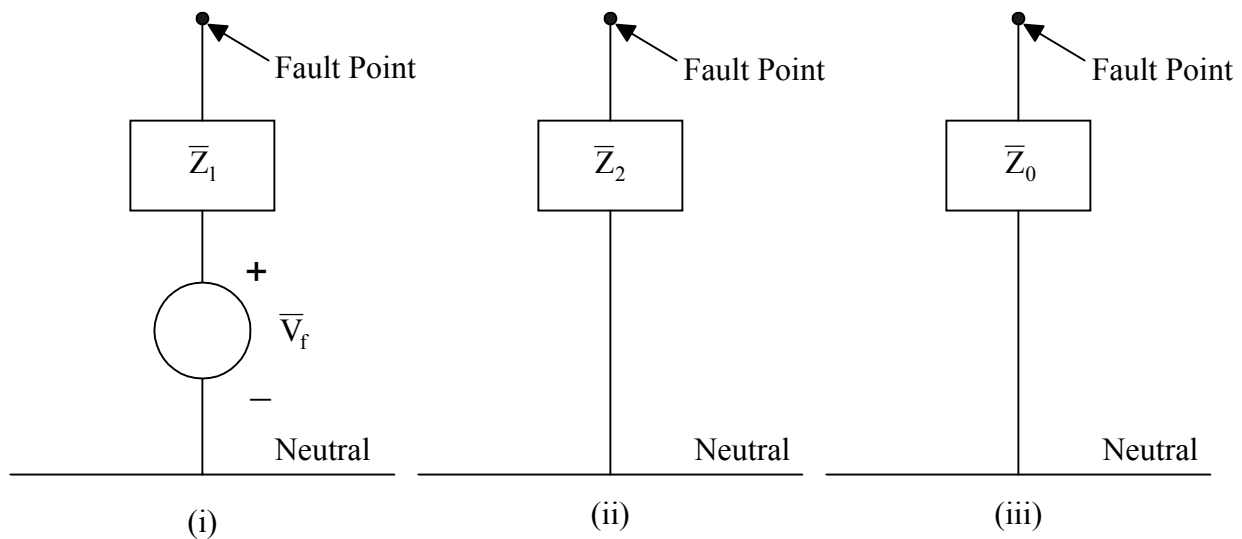

Fig. 4-7. Sequence networks: (i) positive sequence network, (ii) negative sequence network, and (iii) zero sequence network.

Types of common faults

The normal operating mode of a power system is a balanced three-phase AC. However, there are four common faults may cause balanced and/or unbalanced operation conditions. These faults with their associated relative occurrence frequencies are listed in Table 4-1.

Table 4-1. Fault types and their frequencies.

Fault Type	Relative Frequency
Single-line-to-ground (SLG)	70%
Line-to-line (LL)	15%
Line-to-line-to-ground (2LG)	10%
Three-phase (3P)	5%
TOTAL	100%

Sometimes instead of using “line” in these fault types, “phase” is used. For instance, a phase-to-phase fault is the same as a line-to-line fault. This section will derive the connections of sequence networks associated with these four faults.

A three-phase system, as shown in Figure 4-8 is used for the development of sequence networks for different fault conditions. Please note that, as labeled in this figure, the currents \bar{I}_a , \bar{I}_b and \bar{I}_c are not the line currents during normal operating conditions. Instead, these currents are fault currents during various types of faults. Therefore, they have a zero value during normal conditions. It is important to assume that there may be some impedances between lines and the ground involved in various faults while developing the sequence networks.

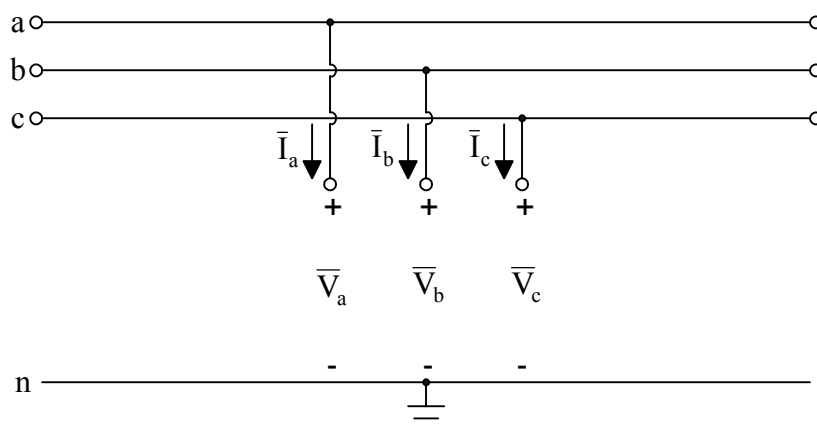

Fig. 4-8. The three-phase system used for sequence network development during various faults.

The first type of faults is the three-phase faults. This is most severe but least likely to occur (5%). Since it is the only balanced fault while the others are unbalanced faults, this is the first one to be presented. It is assumed that the each line is connected to the ground through the impedance \bar{Z}_f , as shown in Figure 4-9.

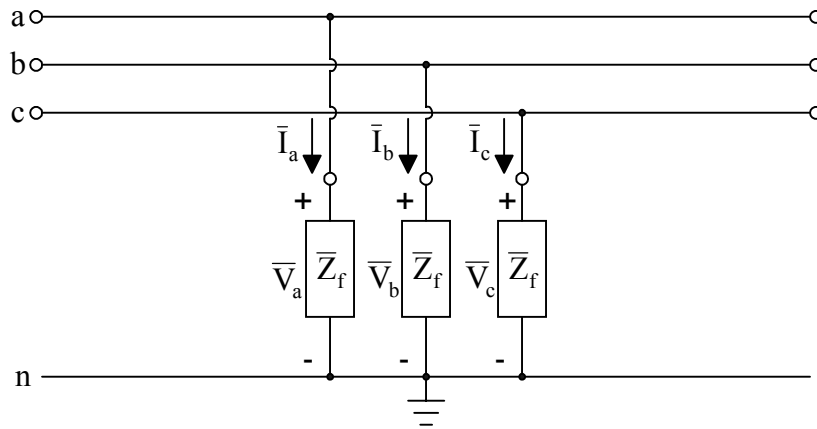

Fig. 4-9. Three-phase (3P) fault representation.

The three phase voltages can be obtained by the products of currents and the impedance \bar{Z}_f , namely,

$$\bar{V}_a = \bar{I}_a \bar{Z}_f,$$

$$\bar{V}_b = \bar{I}_b \bar{Z}_f,$$

and

$$\bar{V}_c = \bar{I}_c \bar{Z}_f.$$

These three equations can be expressed in matrix notation as

$$\begin{bmatrix} \bar{V}_a \\ \bar{V}_b \\ \bar{V}_c \end{bmatrix} = \begin{bmatrix} \bar{Z}_f & 0 & 0 \\ 0 & \bar{Z}_f & 0 \\ 0 & 0 & \bar{Z}_f \end{bmatrix} \begin{bmatrix} \bar{I}_a \\ \bar{I}_b \\ \bar{I}_c \end{bmatrix} = [\tilde{Z}_{abc}] [\tilde{I}_{abc}],$$

where

$$[\tilde{Z}_{abc}] = \begin{bmatrix} \bar{Z}_f & 0 & 0 \\ 0 & \bar{Z}_f & 0 \\ 0 & 0 & \bar{Z}_f \end{bmatrix}.$$

Recall

$$[\tilde{V}_{abc}] = [T] [\tilde{V}_{012}],$$

and

$$[\tilde{I}_{abc}] = [T] [\tilde{I}_{012}],$$

therefore,

$$[T][\tilde{V}_{012}] = [\tilde{Z}_{abc}][T][\tilde{I}_{012}].$$

Multiple both sides by $[T]^{-1}$ (hint: $[T]^{-1}[T] = \begin{bmatrix} 1 & 0 & 0 \\ 0 & 1 & 0 \\ 0 & 0 & 1 \end{bmatrix}$, unity matrix), then,

$$[\tilde{V}_{012}] = [\tilde{Z}_{012}][\tilde{I}_{012}],$$

where

$$[\tilde{Z}_{012}] = [T]^{-1}[\tilde{Z}_{abc}][T] = \frac{1}{3} \begin{bmatrix} 1 & 1 & 1 \\ 1 & a & a^2 \\ 1 & a^2 & a \end{bmatrix} \begin{bmatrix} \bar{Z}_f & 0 & 0 \\ 0 & \bar{Z}_f & 0 \\ 0 & 0 & \bar{Z}_f \end{bmatrix} \begin{bmatrix} 1 & 1 & 1 \\ 1 & a^2 & a \\ 1 & a & a^2 \end{bmatrix} = \begin{bmatrix} \bar{Z}_f & 0 & 0 \\ 0 & \bar{Z}_f & 0 \\ 0 & 0 & \bar{Z}_f \end{bmatrix}.$$

Therefore,

$$\bar{V}_0 = \bar{Z}_f \bar{I}_0,$$

$$\bar{V}_1 = \bar{Z}_f \bar{I}_1,$$

and

$$\bar{V}_2 = \bar{Z}_f \bar{I}_2.$$

The positive sequence network, negative sequence network and zero sequence network for a three-phase fault can be obtained from these equations, and are shown in Figures 4-10, 4-11 and 4-12, respectively. Since there are no voltage sources in negative and zero sequence networks,

$$\bar{V}_{a2} = \bar{V}_{a0} = 0,$$

and

$$\bar{I}_{a2} = \bar{I}_{a0} = 0.$$

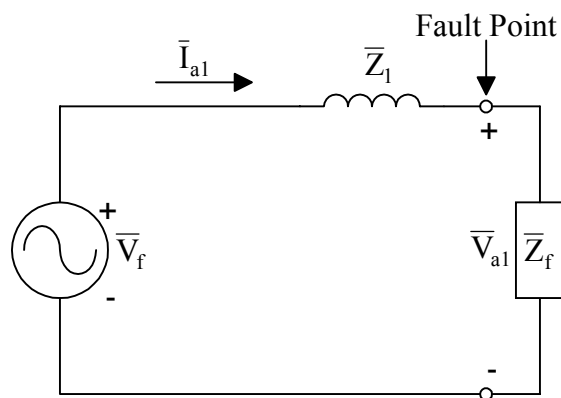

Fig. 4-10. Positive sequence network for a three-phase (3P) fault.

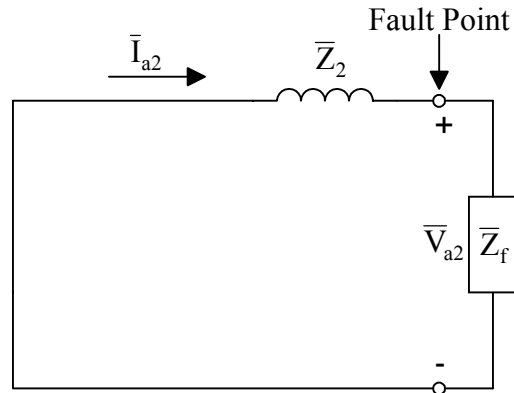

Fig. 4-11. Negative sequence network for a three-phase (3P) fault.

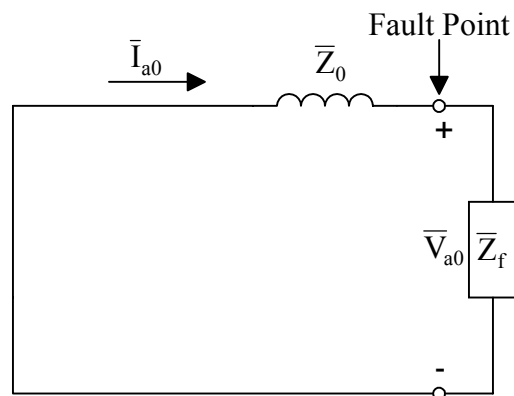

Fig. 4-12. Zero sequence network for a three-phase (3P) fault.

It is clear that for a three-phase fault, there is no need to use negative and zero sequence networks and symmetrical components since only positive sequence network is involved. More importantly, one should realize that a three-phase fault is a balanced fault while the others are unbalanced faults.

The second type of faults to be discussed is the single-line-to-ground (SLG) fault (or phase-to-ground fault). As shown in Figure 4-13, a SLG fault is commonly analyzed with Phase “a” connecting the ground through the fault impedance \bar{Z}_f .

It can be observed from Figure 4-13, that

$$\bar{I}_b = \bar{I}_c = 0,$$

and

$$\bar{V}_a = \bar{I}_a \bar{Z}_f.$$

Recall that

$$\bar{I}_a = \bar{I}_{a0} + \bar{I}_{a1} + \bar{I}_{a2},$$

$$\bar{I}_b = \bar{I}_{b0} + \bar{I}_{b1} + \bar{I}_{b2} = \bar{I}_{a0} + a^2\bar{I}_{a1} + a\bar{I}_{a2},$$

and

$$\bar{I}_c = \bar{I}_{c0} + \bar{I}_{c1} + \bar{I}_{c2} = \bar{I}_{a0} + a\bar{I}_{a1} + a^2\bar{I}_{a2}.$$

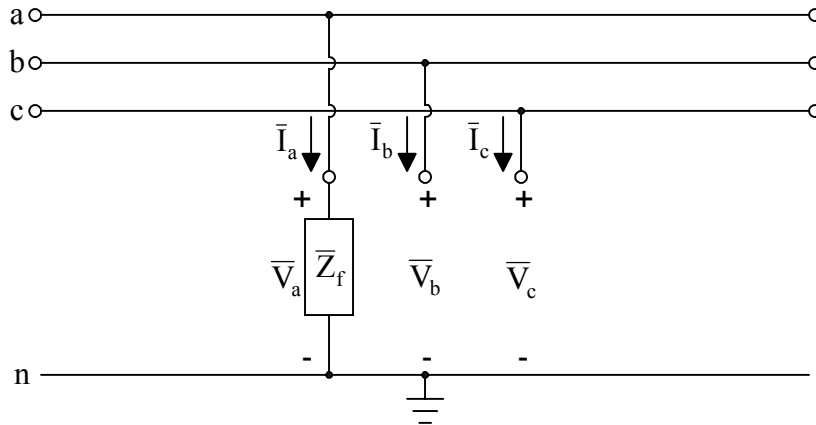

Fig. 4-13. Single-line-to-ground (SLG) fault representation.

Since

$$\bar{I}_b = 0 = \bar{I}_c,$$

therefore,

$$\bar{I}_{a0} + a^2\bar{I}_{a1} + a\bar{I}_{a2} = \bar{I}_{a0} + a\bar{I}_{a1} + a^2\bar{I}_{a2},$$

$$(a^2 - a)\bar{I}_{a1} = (a^2 - a)\bar{I}_{a2}.$$

Finally,

$$\bar{I}_{a1} = \bar{I}_{a2}.$$

Also, since

$$\bar{I}_b = 0,$$

therefore,

$$\bar{I}_{a0} + a^2\bar{I}_{a1} + a\bar{I}_{a2} = 0,$$

$$\bar{I}_{a0} + (a^2 + a)\bar{I}_{a1} = 0,$$

$$\bar{I}_{a0} = -(a^2 + a)\bar{I}_{a1} = -(a^2 + a + 1)\bar{I}_{a1} + \bar{I}_{a1}.$$

Finally,

$$\bar{I}_{a0} = \bar{I}_{a1} = \bar{I}_{a2}.$$

Recall the fault voltage

$$\bar{V}_a = \bar{I}_a \bar{Z}_f \Rightarrow (\bar{V}_{a0} + \bar{V}_{a1} + \bar{V}_{a2}) = (\bar{I}_{a0} + \bar{I}_{a1} + \bar{I}_{a2}) \bar{Z}_f = 3\bar{Z}_f \bar{I}_{a1}$$

From the last two equations, one can determine the connection between positive, negative and zero sequence networks for a single-line-to-ground (SLG) fault, and is shown in Figure 4-14.

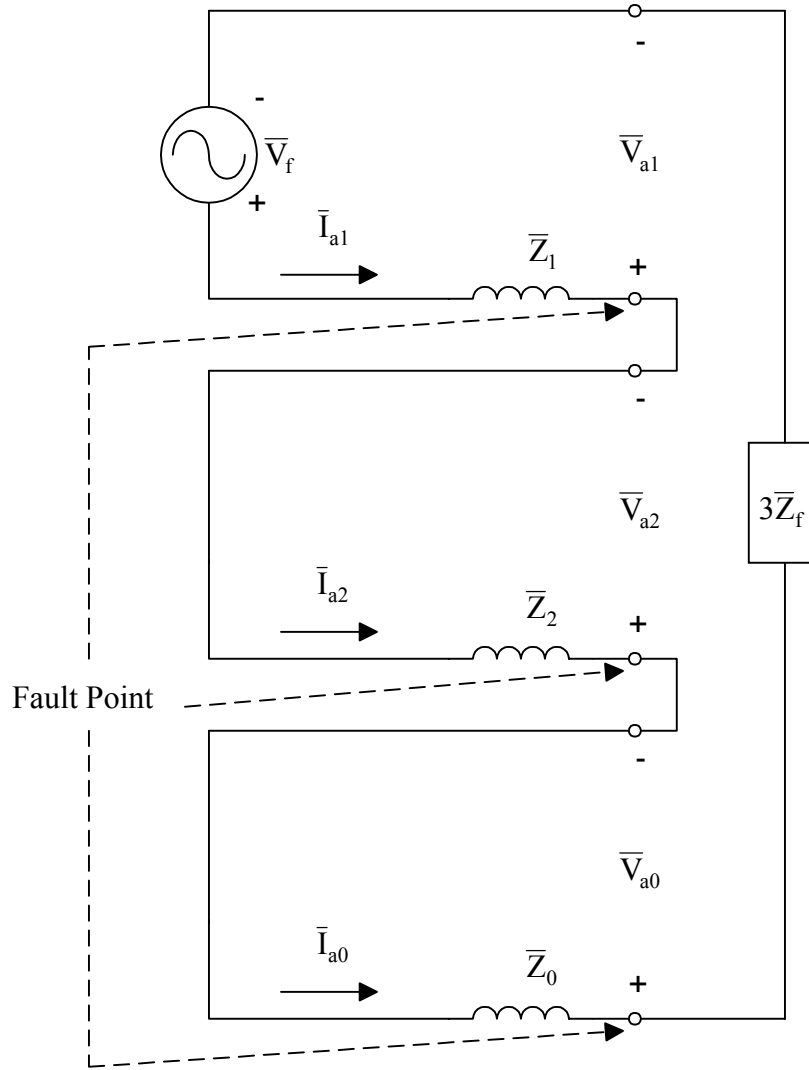

Fig. 4-14. Sequence network connection for a single-line-to-ground (SLG) fault.

The next type of faults to be discussed is the line-to-line (LL) fault, or phase-to-phase fault. It is commonly analyzed as Phases “b” and “c” connected together through the fault impedance \bar{Z}_f while the Phase “a” is open, as shown in Figure 4-15.

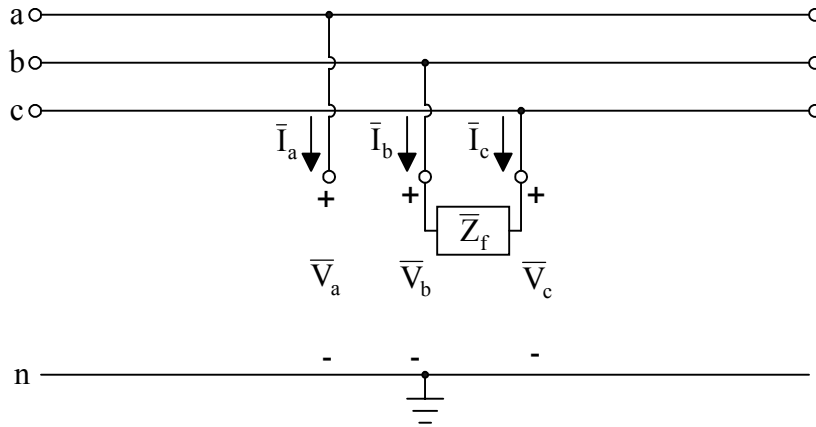

Fig. 4-15. Line-to-line (LL) fault representation.

The following facts can be observed from Figure 4-15.

$$\bar{I}_a = 0,$$

$$\bar{I}_b = -\bar{I}_c,$$

and

$$\bar{V}_b = \bar{Z}_f \bar{I}_b + \bar{V}_c.$$

From the first equation,

$$\bar{I}_a = 0 \Rightarrow (\bar{I}_{a0} + \bar{I}_{a1} + \bar{I}_{a2}) = 0 \Rightarrow \bar{I}_{a1} + \bar{I}_{a2} = -\bar{I}_{a0}.$$

From the second equation,

$$\bar{I}_b = -\bar{I}_c \Rightarrow \bar{I}_{a0} + a^2 \bar{I}_{a1} + a \bar{I}_{a2} = -(\bar{I}_{a0} + a \bar{I}_{a1} + a^2 \bar{I}_{a2}) \Rightarrow 2\bar{I}_{a0} + (a^2 + a)(\bar{I}_{a1} + \bar{I}_{a2}) = 0.$$

The conclusion from the first equation can be applied,

$$2\bar{I}_{a0} + (a^2 + a)(-\bar{I}_{a0}) = 0 \Rightarrow 3\bar{I}_{a0} = 0 \Rightarrow \bar{I}_{a0} = 0.$$

Therefore,

$$\bar{I}_{a1} = -\bar{I}_{a2}.$$

From the third equation,

$$\bar{V}_{a0} + a^2 \bar{V}_{a1} + a \bar{V}_{a2} = \bar{Z}_f (\bar{I}_{a0} + a^2 \bar{I}_{a1} + a \bar{I}_{a2}) + \bar{V}_{a0} + a \bar{V}_{a1} + a^2 \bar{V}_{a2},$$

then,

$$(a^2 - a) \bar{V}_{a1} = (a^2 - a) \bar{I}_{a1} \bar{Z}_f + (a^2 - a) \bar{V}_{a2}.$$

Therefore,

$$\bar{V}_{a1} = \bar{I}_{a1} \bar{Z}_f + \bar{V}_{a2}.$$

The sequence network for a line-to-line (LL) fault can be obtained, and, is shown in Figure 4-16.

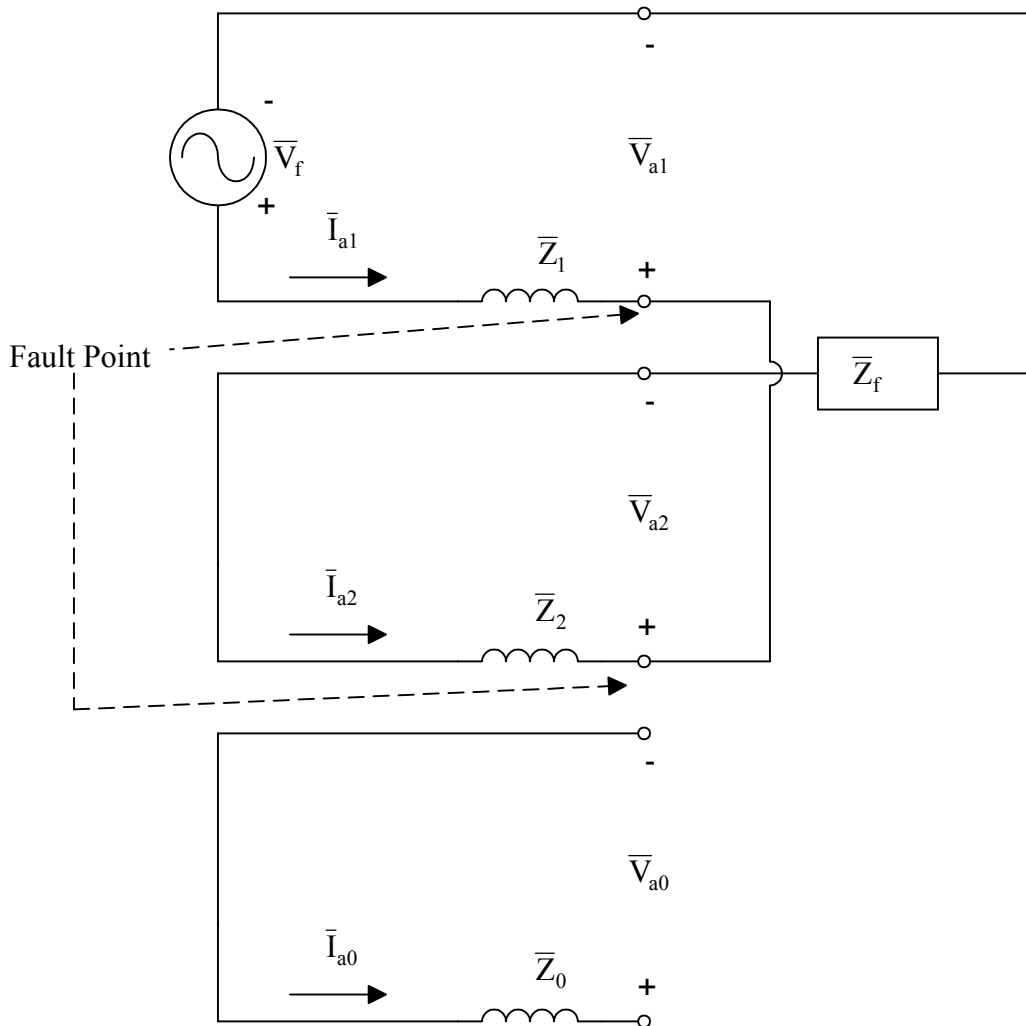

Fig. 4-16. Sequence network connection for a line-to-line (LL) fault.

The last common type of faults is the line-to-line-to-ground (2LG) fault. Usually the analysis of this type of faults is done with the assumption of Phases “b” and “c” shorted together, then, connected the ground through the impedance \bar{Z}_f , while Phase “a” is open, as shown in Figure 4-17.

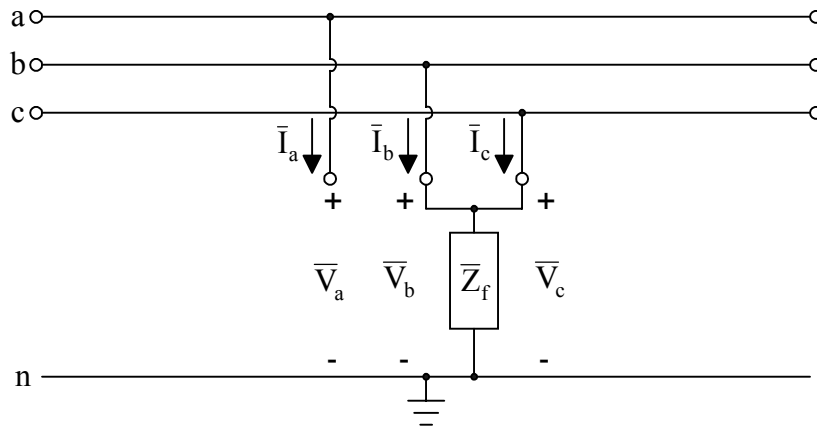

Fig. 4-17. Line-to-line-to-ground (2LG) fault representation.

The following three facts can be observed from Figure 4-17:

$$\bar{I}_a = 0,$$

$$\bar{V}_b = \bar{V}_c,$$

and

$$\bar{V}_b = (\bar{I}_b + \bar{I}_c)\bar{Z}_f.$$

From the first equation,

$$\bar{I}_{a1} + \bar{I}_{a2} = -\bar{I}_{a0}.$$

From the second equation,

$$\bar{V}_{a0} + a^2\bar{V}_{a1} + a\bar{V}_{a2} = \bar{V}_{a0} + a\bar{V}_{a1} + a^2\bar{V}_{a2} \Rightarrow (a^2 - a)\bar{V}_{a1} = (a^2 - a)\bar{V}_{a2} \Rightarrow \bar{V}_{a1} = \bar{V}_{a2}.$$

Finally, from the third equation,

$$\bar{V}_{a0} + a^2\bar{V}_{a1} + a\bar{V}_{a2} = (\bar{I}_{a0} + a^2\bar{I}_{a1} + a\bar{I}_{a2} + \bar{I}_{a0} + a\bar{I}_{a1} + a^2\bar{I}_{a2})\bar{Z}_f,$$

Then,

$$\bar{V}_{a0} + (a^2 + a)\bar{V}_{a1} = [2\bar{I}_{a0} + (a^2 + a)(\bar{I}_{a1} + \bar{I}_{a2})]\bar{Z}_f \Rightarrow \bar{V}_{a0} - \bar{V}_{a1} = 3\bar{I}_{a0}\bar{Z}_f.$$

With the results from the above derivations, one can construct the connection between the sequence networks for a line-to-line-to-ground (2LG) fault as shown in Figure 4-18.

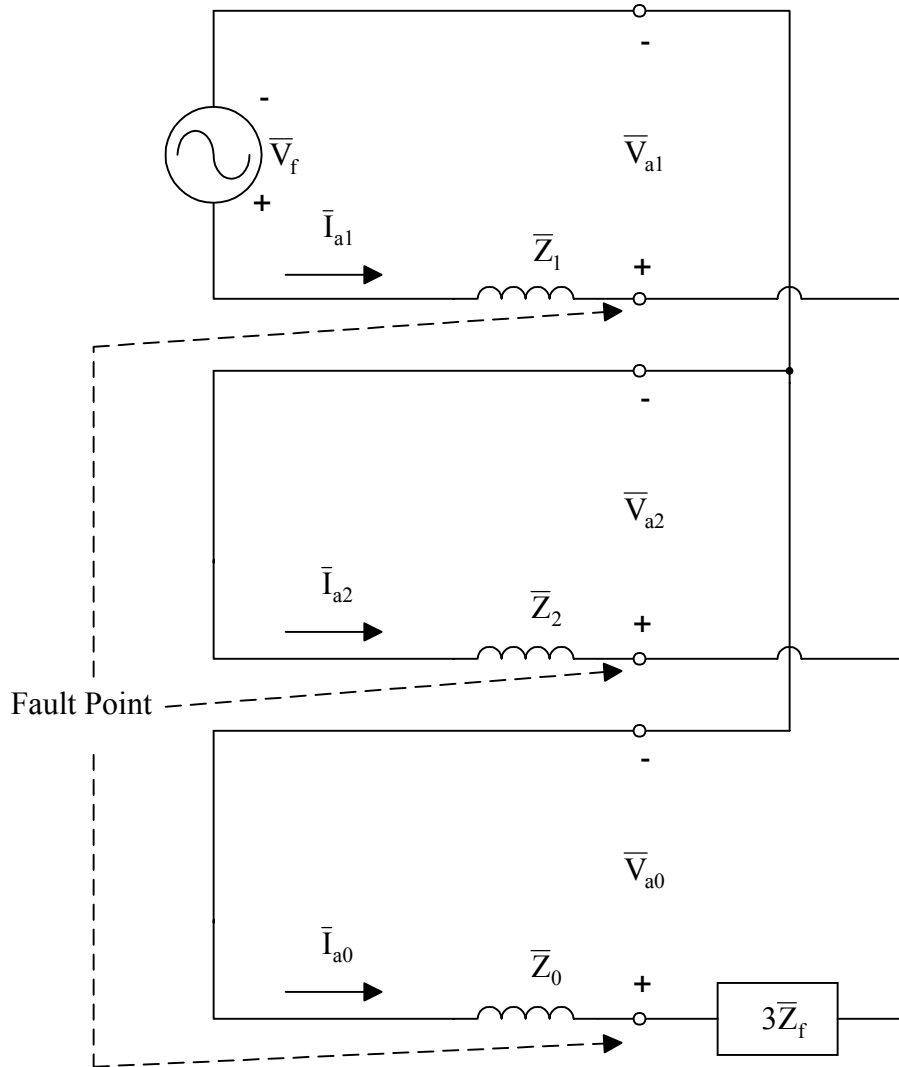

Fig. 4-18. Sequence network connection for a line-to-line-to-ground (2LG) fault.

Recall that the sequence networks for four types of fault are obtained with the assumption of the existence of the fault impedance \bar{Z}_f . However, in some situations, the calculations may be done with a direct shorted fault. In such cases $\bar{Z}_f = 0$. It implies that a short circuit needs to replace the \bar{Z}_f for all of the four sequence network connections.

To summarize the discussion on the four common types of faults:

- i. Three-phase (3P) faults (a-b-c-ground shorted) - Positive sequence only.
- ii. Single-line-to-ground (SLG) faults (a-ground) - Positive sequence, negative sequence and zero sequence.
- iii. Line-to-line (LL) faults (b-c shorted) - Positive sequence and negative sequence.
- iv. Line-to-line-to-ground (2LG) faults (b-c-ground) - Positive sequence, negative sequence and zero sequence.

The following simplified sequence network connections, as shown in Figure 4-19, are for the four types of faults with $\bar{Z}_f = 0$.

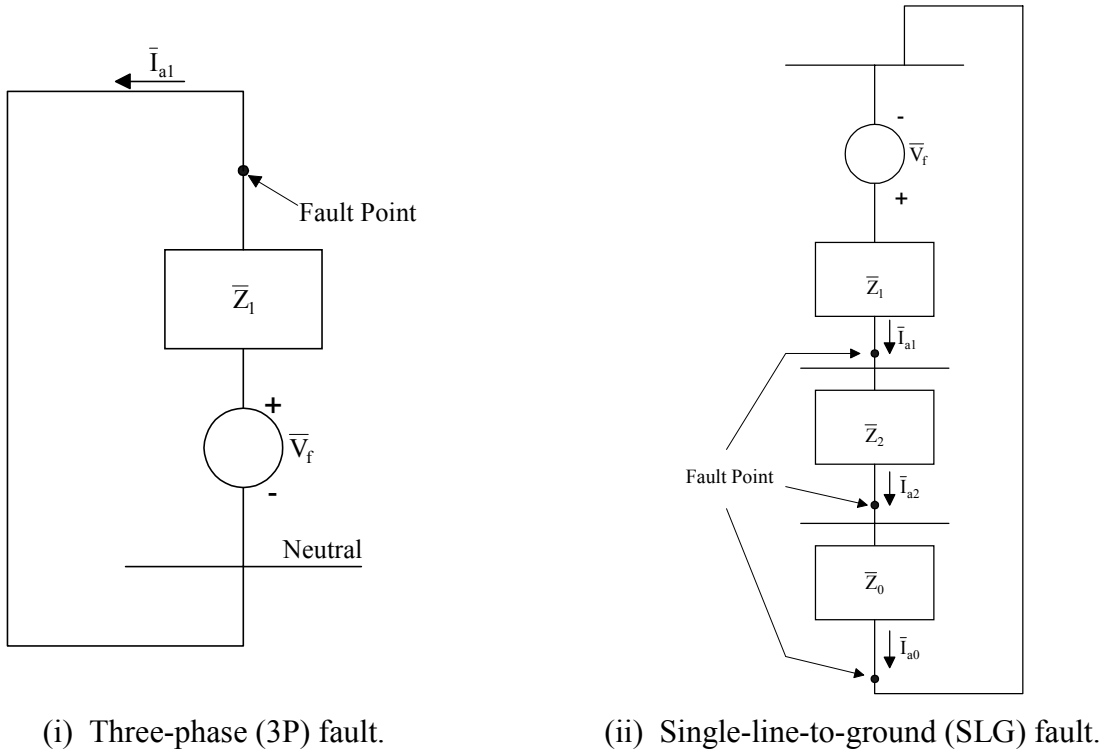

(i) Three-phase (3P) fault.

(ii) Single-line-to-ground (SLG) fault.

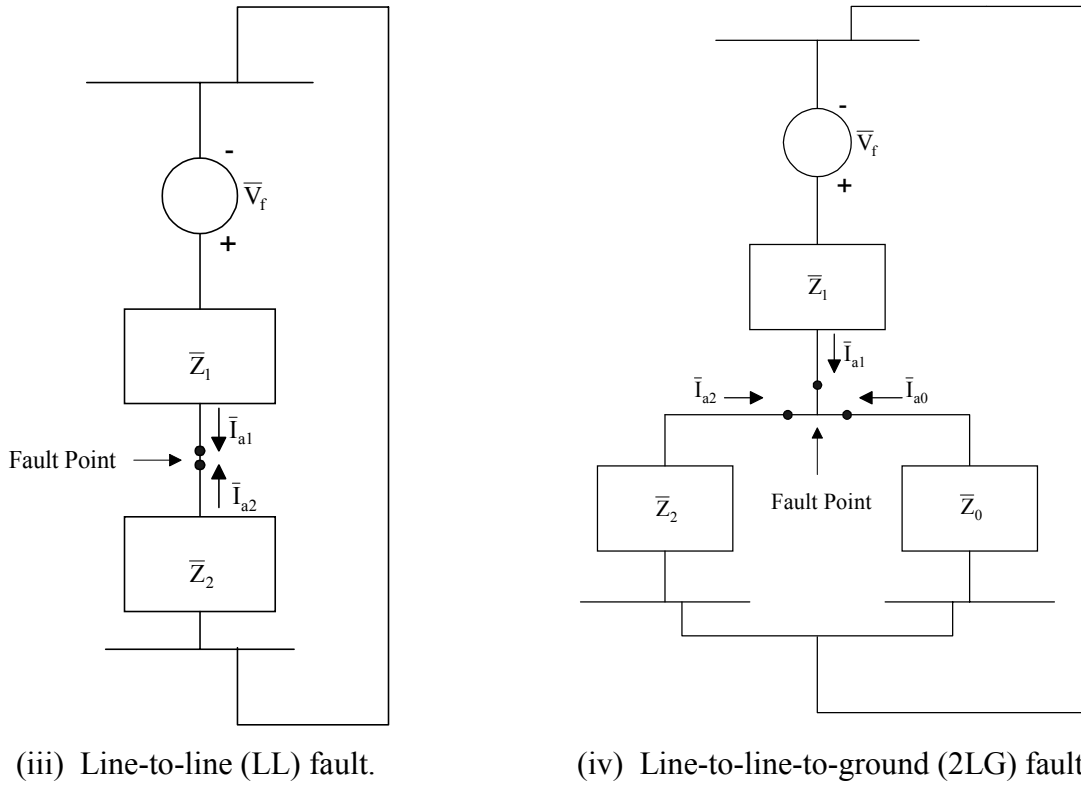

(iii) Line-to-line (LL) fault.

(iv) Line-to-line-to-ground (2LG) fault.

Fig. 4-19. Summary of sequence network connections for four common faults.

Short Circuit Calculations

To calculate the short circuit fault currents, use proper connection of sequence networks to compute sequence quantities at a specified fault point for any specific type of fault. Only simple network analysis is required. Then use relations discussed in this module to transform sequence quantities to phase quantities.

Example 4-3: A Single-line-to-ground fault occurs in a 138 kV system. System impedances to the left of the fault point are

$$X_1 = X_2 = 6\Omega \text{ and } X_0 = 4\Omega$$

System impedances to the right of the fault point are

$$X_1 = X_2 = 8\Omega \text{ and } X_0 = 5\Omega$$

Compute the fault current in phases of system and the current to the left of fault after it occurs.

Solution:

The connection of positive sequence network, negative sequence network and zero sequence network for the SLG fault given can be shown in Figure 4-20.

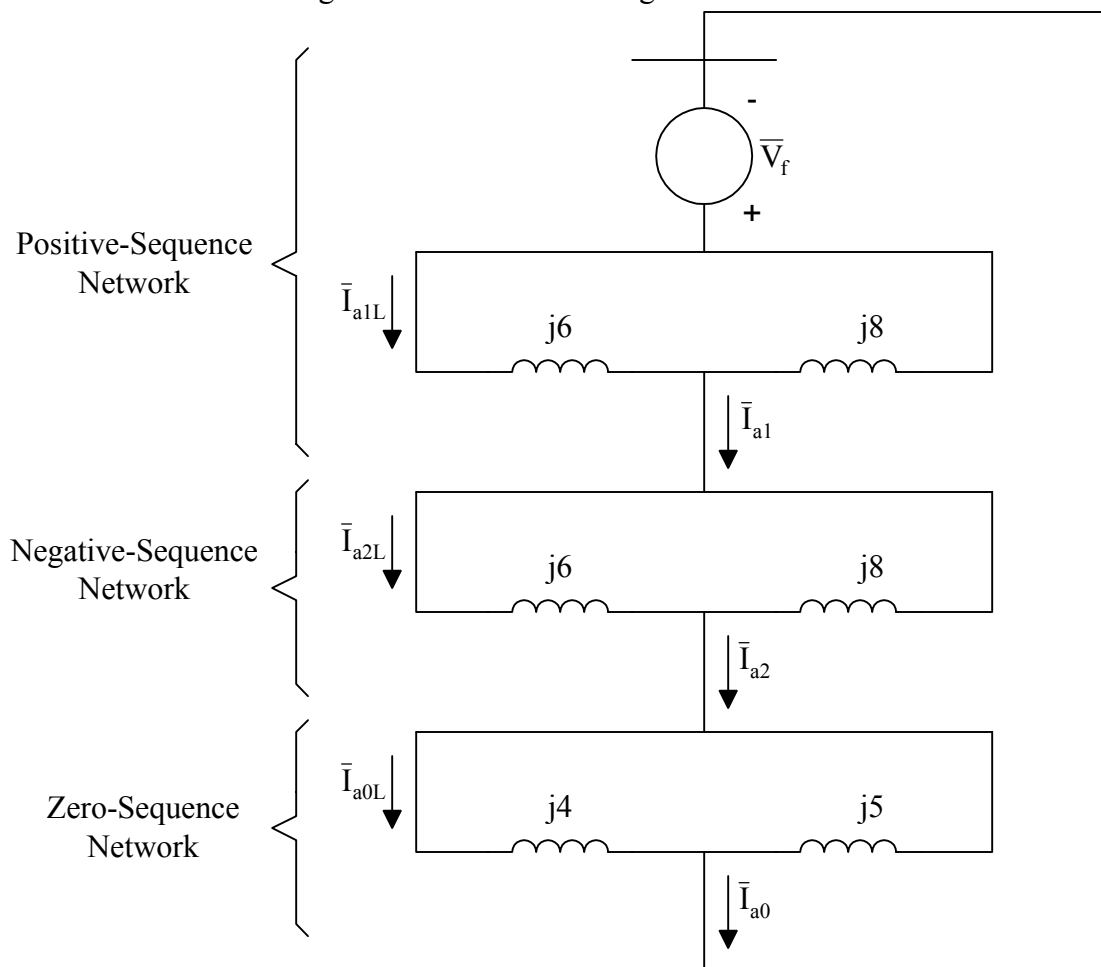

Fig. 4-20. The connection of positive, negative and zero sequence networks for SLG fault.

Use per phase analysis, and assume that the pre-fault source voltage is the rated voltage,

$$\bar{V}_f = \frac{138000\angle 0^\circ}{\sqrt{3}} \text{ pu}$$

$$\bar{Z}_1 = \frac{(j6)(j8)}{j6 + j8} = j3.429\Omega = \bar{Z}_2$$

$$\bar{Z}_0 = \frac{(j4)(j5)}{j4 + j5} = j2.222\Omega$$

$$\bar{I}_{a1} = \bar{I}_{a2} = \bar{I}_{a0} = \frac{\bar{V}_f}{\bar{Z}_1 + \bar{Z}_2 + \bar{Z}_0} = \frac{(138000\angle 0^\circ / \sqrt{3})}{j(3.429 + 3.429 + 2.222)} = -j8775 \text{ amps}$$

To calculate the phase current at the fault, convert sequence quantities to phase quantities:

$$\begin{bmatrix} \bar{I}_a \\ \bar{I}_b \\ \bar{I}_c \end{bmatrix} = \begin{bmatrix} 1 & 1 & 1 \\ 1 & a^2 & a \\ 1 & a & a^2 \end{bmatrix} \begin{bmatrix} \bar{I}_{a0} \\ \bar{I}_{a1} \\ \bar{I}_{a2} \end{bmatrix} = \begin{bmatrix} 1 & 1 & 1 \\ 1 & a^2 & a \\ 1 & a & a^2 \end{bmatrix} \begin{bmatrix} -j8775 \\ -j8775 \\ -j8775 \end{bmatrix} = \begin{bmatrix} 3 \times (-j8775) \\ (1 + a^2 + a)(-j8775) \\ (1 + a + a^2)(-j8775) \end{bmatrix} = \begin{bmatrix} -j26324 \\ 0 \\ 0 \end{bmatrix}$$

In the left of the fault, the sequence currents:

$$\bar{I}_{a1L} = \bar{I}_{a2L} = \frac{j8}{j6 + j8} (-j8775) = -j5014 \text{ amps}$$

$$\bar{I}_{a0L} = \frac{j5}{j4 + j5} (-j8775) = -j4875 \text{ amps}$$

Therefore, the phase (line) currents to the left of fault:

$$\begin{bmatrix} \bar{I}_{aL} \\ \bar{I}_{bL} \\ \bar{I}_{cL} \end{bmatrix} = \begin{bmatrix} 1 & 1 & 1 \\ 1 & a^2 & a \\ 1 & a & a^2 \end{bmatrix} \begin{bmatrix} \bar{I}_{a0L} \\ \bar{I}_{a1L} \\ \bar{I}_{a2L} \end{bmatrix} = \begin{bmatrix} 1 & 1 & 1 \\ 1 & a^2 & a \\ 1 & a & a^2 \end{bmatrix} \begin{bmatrix} -j5014 \\ -j5014 \\ -j4875 \end{bmatrix} = \begin{bmatrix} -j14903 \\ j139 \\ j139 \end{bmatrix} \text{ amps}$$

Figure 4-21 shows a graphical representation of these quantities.

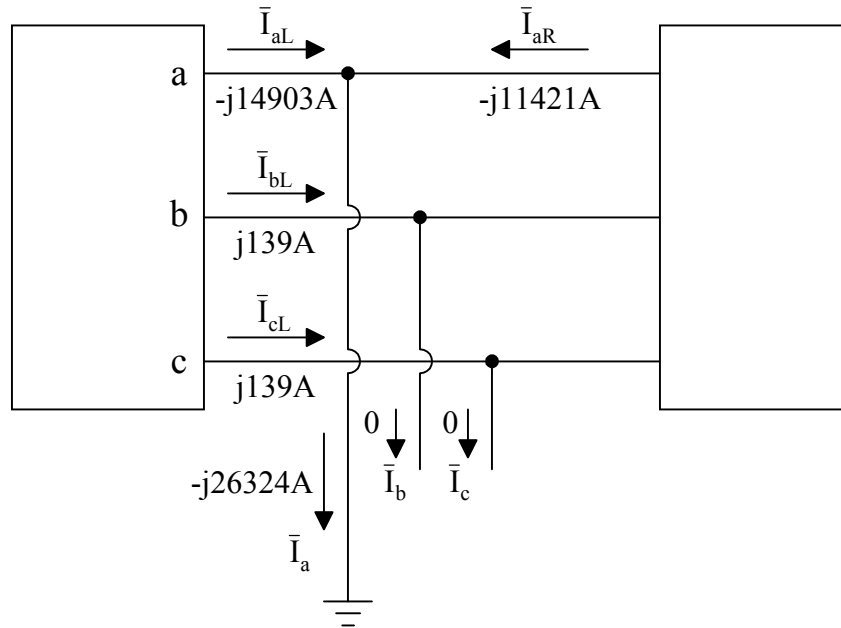

Fig. 4-21. Single-line-to-ground (SLG) fault.

◆

The example given has assumed that the impedances of positive sequence, negative sequence and zero sequence networks at fault were found already. However, it may not be practical. The example was intended to show the readers how symmetrical components can be applied for an unbalanced fault condition, and how simple the problem can be solved if the sequence networks were obtained. The real challenge for design engineers and field engineers is to obtain these sequence networks, mainly, the zero sequence networks.

The main troubles on setting up the zero sequence networks are the three-phase transformers with various configurations. Three-phase transformers are commonly connected in wye ungrounded, wye grounded and delta on each winding. For instance, a two winding transformer may be connected as one of the followings five configurations:

1. wye grounded – wye.
2. wye grounded – wye grounded.
3. wye grounded – delta.
4. wye – delta.
5. delta – delta.

Their corresponding zero sequence networks are listed in Figure 4-22.

Symbols	Connection Diagrams	Zero-Sequence Equivalent circuits
		
		
		
		
		

Fig. 4-22. Zero sequence equivalent circuits of three-phase transformer banks together with diagrams of connections and the symbols for one-line diagrams.

The following is a step-by-step procedure on how to set up the sequence networks at fault. Consider the following system, as shown in Figure 4-23,

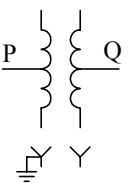
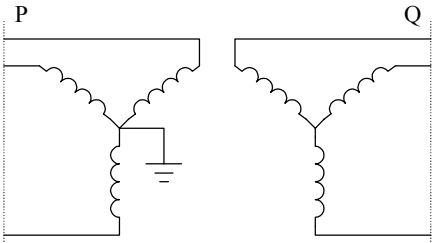
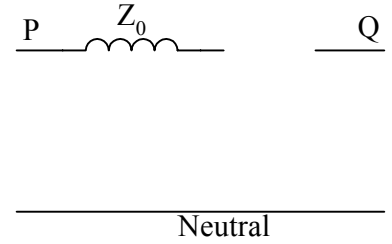
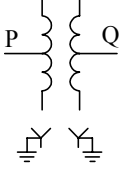
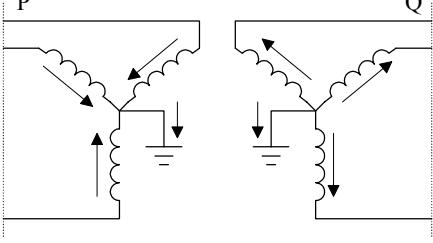
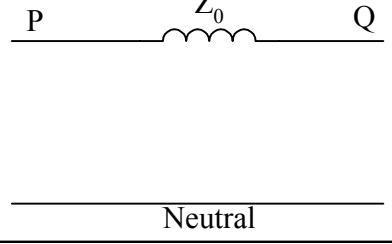
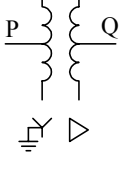
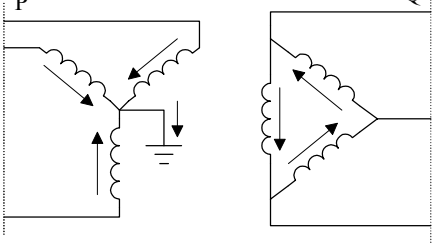
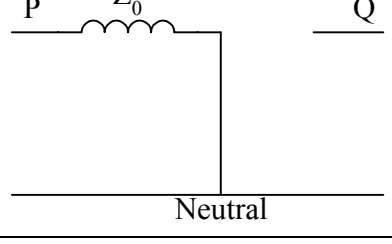
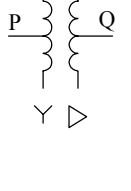
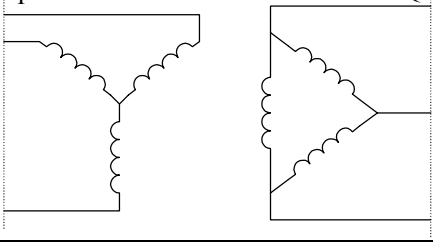
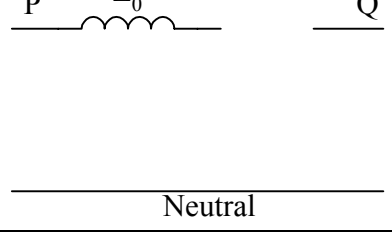
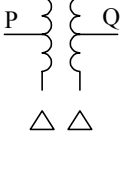
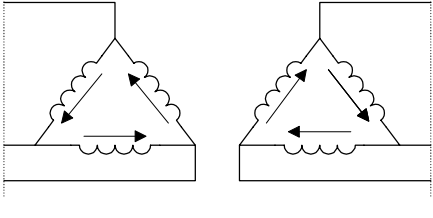
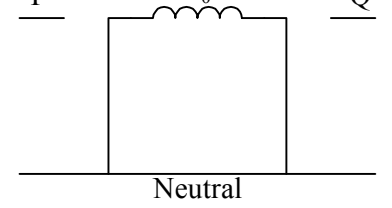
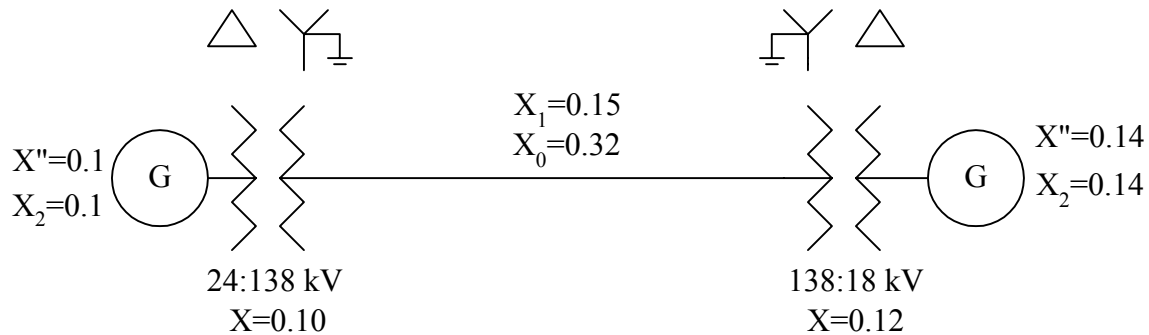

Fig. 4-23. The one-line diagram for the simple three-phase system.

For generators: $X'' = X''_d$ = (direct-axis) sub-transient synchronous reactance, X' = (direct-axis) transient synchronous reactance and X = (direct-axis) synchronous reactance. For short circuit calculations, X'' is used as the positive sequence reactance, X_1 , and in general, $X_1 \neq X_2$.

Modeling of the above system for short-circuit calculations:

- i. Positive sequence network:

The pre-fault voltages for both generators are assumed to be the same, and are commonly set to be at their rated voltages. It is important to remind readers that various equivalent circuits shown in Figure 4-22 are only for zero sequence networks not for positive/negative sequence networks. The positive sequence for the simple system is shown in Figure 4-24. This network can be reduced to a voltage source, \bar{V}_f , and its positive sequence impedance, \bar{Z}_1 , as shown in Figure 4-25. The fault point is still to be determined.

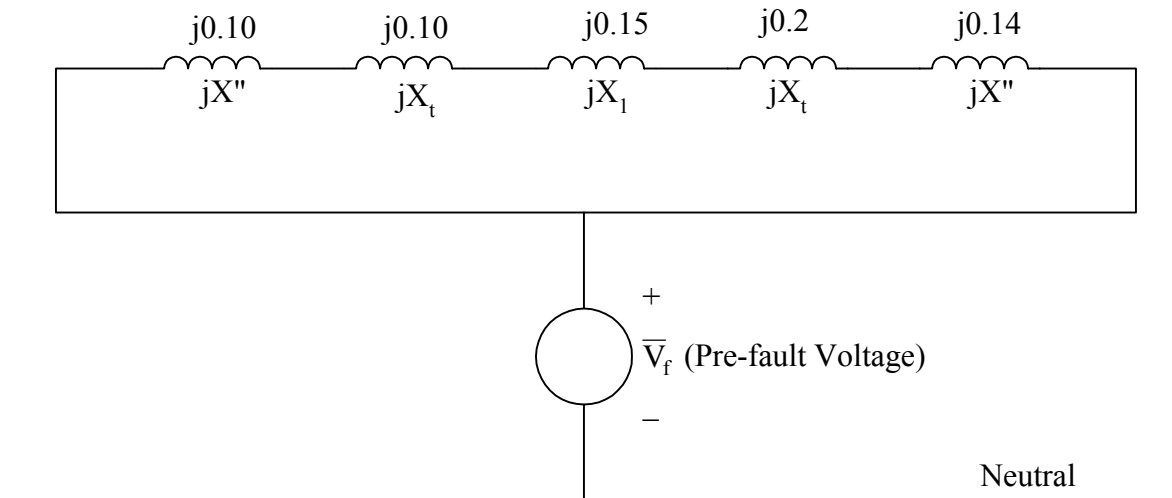

Fig. 4-24. The positive sequence network for the simple system.

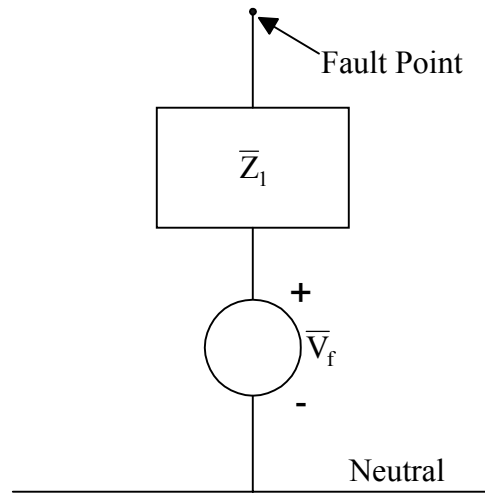

Fig. 4-25. Reduced positive sequence network.

ii. Negative sequence network:

Similarly, the negative sequence can be obtained and are shown in Figure 4-26. Normally the difference between the positive and negative sequence networks is that the negative sequence network does not contain any voltage source. The negative sequence network can be reduced and is shown in Figure 4-27. Again, the fault point is to be determined.

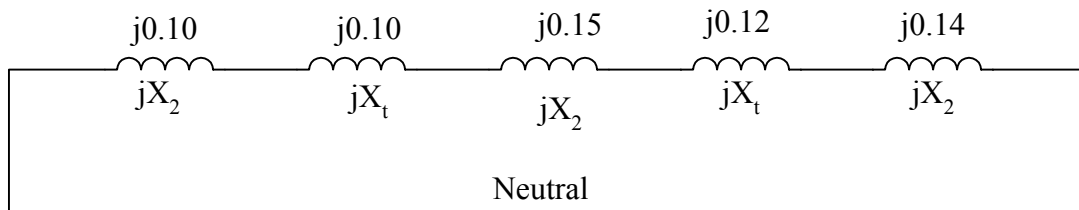

Fig. 4-26. The negative sequence network for the simple system.

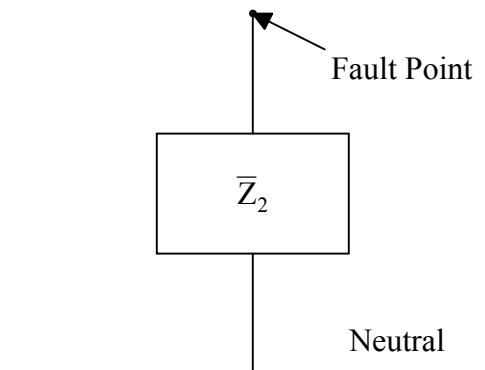

Fig. 4-27. Reduced negative sequence network.

iii. Zero sequence network:

The equivalent circuits given in Figure 4-22 can be very useful for setting up the zero sequence network. Since both transformers are configured as wye grounded – delta with generators connected to the delta side, the third equivalent circuit in Figure 4-22 should be applied with generator impedances connecting to an open circuit, as shown in Figure 4-28. It is worth mentioning that the zero sequence impedances for generators are not given in the simple system since they would not be considered anyway.

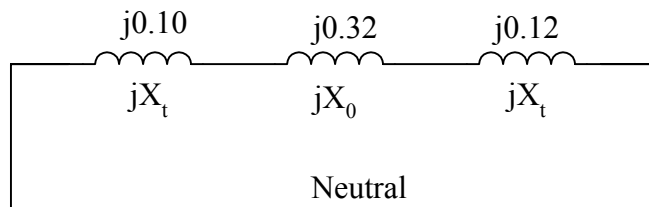

Fig. 4-28. The zero sequence network for the simple system.

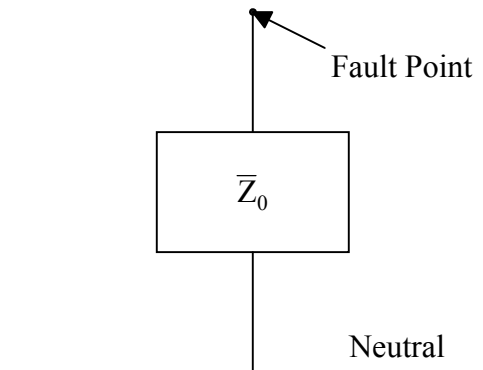
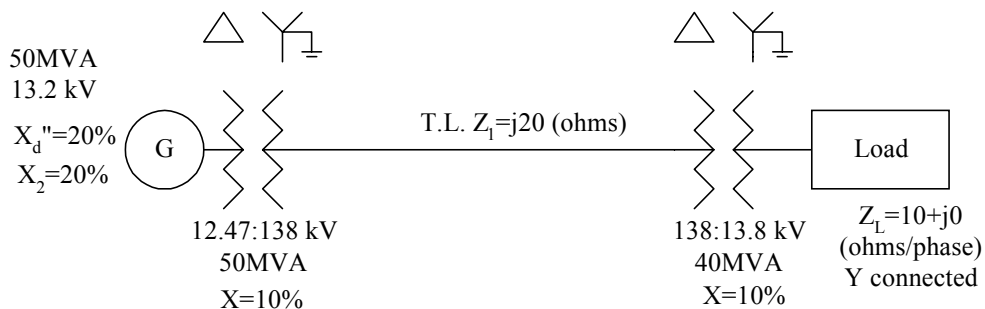

Fig. 4-29. Reduced zero sequence network.

Example 4-4. Given a system as shown below:



- (1) Compute three-phase (3 ϕ) fault current at the load. (same as Example 2-5)
- (2) Compute line-to-line (LL: b-c) fault current at the load and the voltage (magnitude) of Phase b.
- (3) Draw circuit for calculation of single-line-to-ground (SLG) fault at the load.

(4) Before the fault, assuming the load on and operating at 13.8 kV line-to-line, compute the voltage at generator terminals.

Solution:

(1) Select $S_{\text{Base},3\phi} = 50\text{MVA}$ and $V_{\text{Base,L}} = 138\text{kV}$ at the transmission line.

At transmission line section,

$$S_{\text{Base}} = \frac{S_{\text{Base},3\phi}}{3} = \frac{50}{3} = 16.66667 \text{ MVA}$$

$$V_{\text{Base}} = \frac{V_{\text{Base,L}}}{\sqrt{3}} = \frac{138}{\sqrt{3}} = 79.6743 \text{ kV}$$

$$I_{\text{Base}} = \frac{16.66667}{79.6743} = 0.209185 \text{ kA}$$

$$Z_{\text{Base}} = \frac{79.6743}{0.209185} = 380.88 \ \Omega$$

Similarly, the base values at the generator section and load section can be obtained and tabulated in Table 4-1.

Table 4-1. Base values at different sections of the given system.

Location	S_{Base} (MVA)	V_{Base} (kV)	I_{Base} (kA)	Z_{Base} (Ω)
Generator	16.66667	7.1996	2.31494	3.11
Transmission Line	16.66667	79.6743	0.209185	380.88
Load	16.66667	7.96743	2.09185	3.8088

$$X_G = (0.2) \left(\frac{13.2}{12.47} \right)^2 = 0.2241016 \text{ pu}$$

$$X_{T1} = 0.1 \text{ pu}$$

$$X_{T2} = (0.1) \left(\frac{50}{40} \right) = 0.125 \text{ pu}$$

$$X_{TL} = \frac{20}{380.88} = 0.05251 \text{ pu}$$

The generator voltage at pre-fault is 13.2 kV, and its per unit value is

$$\bar{V}_G = \frac{13.2 \angle 0^\circ}{12.47} = 1.05854 \angle 0^\circ \text{ pu}$$

The equivalent circuit for the given system with a three-phase fault at load terminals is shown in Figure 4-30.

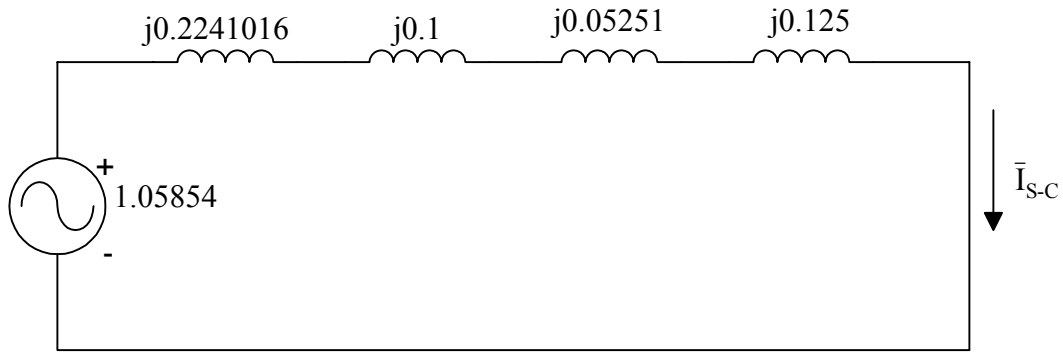

Fig. 4-30. The equivalent circuit for a three-phase fault at load terminals.

Neglect load current, assume generator generating 13.2 kV line-to-line before fault.

$$\bar{I}_{S-C} = \frac{1.05854}{j(0.2241016 + 0.1 + 0.05251 + 0.125)} = -j2.11028 \text{ pu}$$

The three-phase fault current at the load terminals:

$$\bar{I}_{S-C, \text{load}} = (-j2.11028)(2.09185) = -j4.4143892 \text{ kA}$$

(2) Line-to-line fault: The connection between sequence networks for a LL fault is shown in Figure 4-31.

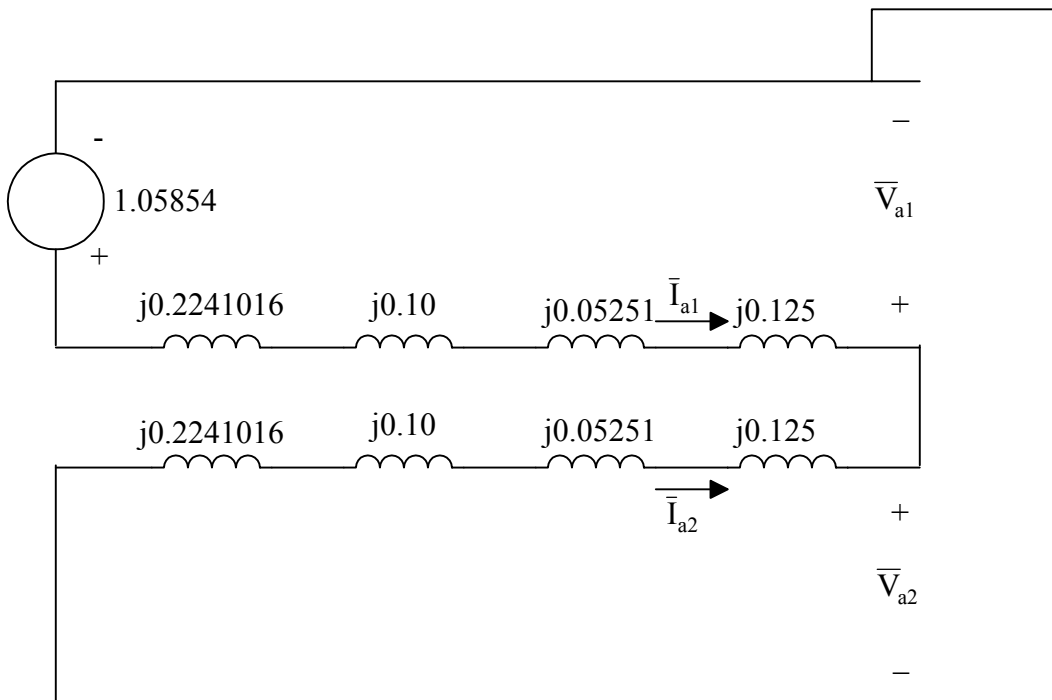

Fig. 4-31. Connection of sequence networks for a LL fault at load terminals.

$$\bar{Z}_1 = \bar{Z}_2 = j(0.2241016 + 0.1 + 0.05251 + 0.125) = j0.5016116 \text{ pu}$$

$$\bar{I}_{a1} = -\bar{I}_{a2} = \frac{1.05854}{2 \times (j0.5016116)} = -j1.0551391 \text{ pu}$$

$$\bar{I}_b = 0 + a^2 \bar{I}_{a1} + a \bar{I}_{a2} = (a^2 - a) \bar{I}_{a1} = (1 \angle -120^\circ - 1 \angle 120^\circ)(-j1.0551391) = -1.8275545 \text{ pu}$$

Therefore, the fault current at load terminals in amps

$$\bar{I}_b = 1.8275545 \times 2091.85 = 3823 \text{ amps}$$

$$\bar{V}_{a1} = \bar{V}_{a2} = 1.05854 - (j0.5016116)(-j1.0551391) = 0.5293 \text{ pu}$$

$$\bar{V}_b = 0 + a^2 \bar{V}_{a1} + a \bar{V}_{a2} = (a^2 + a) \bar{V}_{a1} = -\bar{V}_{a1} = -0.5293 \text{ pu}$$

To get the phase voltage magnitude in kV,

$$V_b = 0.5293 \times 7.96743 = 4.21716 \text{ kV}$$

- (3) Single-line-to-ground fault: The connection between sequence networks for a SLG fault is shown in Figure 4-32.

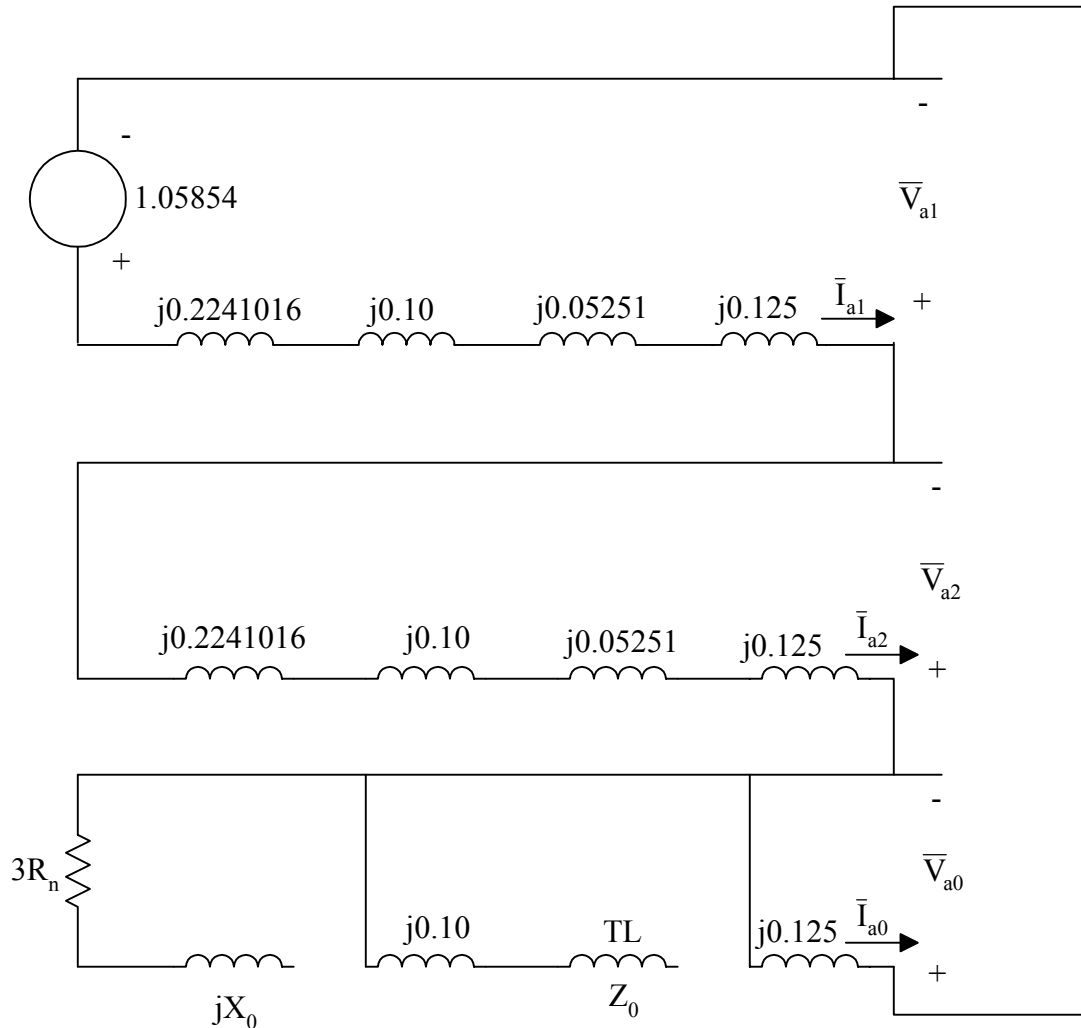

Fig. 4-32. Connection of sequence networks for a SLG fault at load terminals.

- (4) Assume the load is on and operating at 13.8 kV line-to-line. To compute the voltage at the generator terminals, a per phase equivalent circuit of the given system, as show in Figure 4-33, can be obtained.

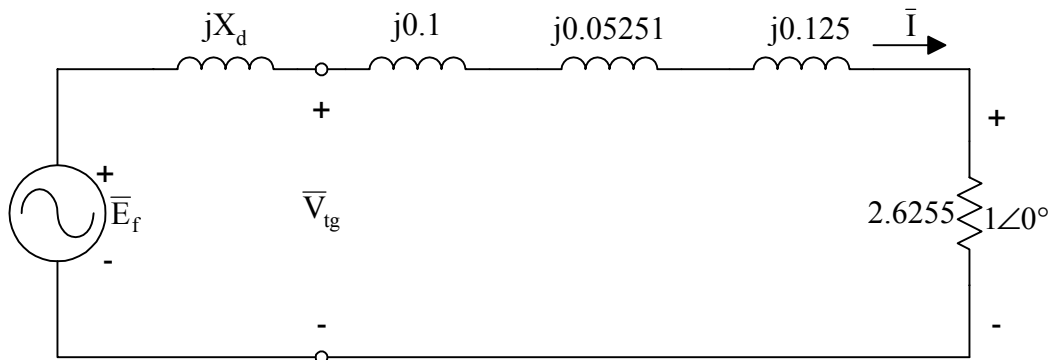

Fig. 4-33. The per phase pre-fault equivalent circuit for the given system.

The load impedance in per unit can be calculated as

$$\bar{Z} = \frac{10}{3.8088} = 2.6255 \text{ pu}$$

The pre-fault load current

$$\bar{I} = \frac{1\angle 0^\circ}{2.6255} = 0.3809 \text{ pu}$$

The phase voltage at the generator terminals

$$\bar{V}_{\text{tg}} = 1 + (j0.1 + 0.05251 + j0.125)(0.3809) = 1.0056\angle 6^\circ \text{ pu}$$

The line-to-line voltage at the generator terminals

$$V_{\text{tg,L}} = 1.0056 \times 12.47 = 12.54 \text{ kV}$$



Accounting for Load Currents

Ordinarily, load currents are ignored in short-circuit calculations. However, if it is desired to take the load current into account in any element, simply add the pre-fault current in that element to the phase current in that element as computed from fault conditions.