

Power Systems - Basic Concepts and Applications

Part I

By Shih-Min Hsu, Ph.D., P.E.

MODULE 2: Basic Concepts - Components of Power Systems.

Overview

This module discusses the main components of power systems. As shown in Figure 1-1, generators, transmission lines and transformers are the three main components of power systems, and will be discussed in this module. Also, a short paper, titled “Utilization of Generator Reactive Capability: A Transmission Viewpoint” as given in Appendix 2A, discusses how the impedance of GSU and the tap setting would affect the ability of reactive production ability of a generator.

Generators

The device converts mechanical energy to electrical energy is called a generator. Synchronous machines can produce high power reliably with high efficiency, and therefore, are widely used as generators in power systems. A generator serves two basic functions. The first one is to produce active power (MW), and the second function, frequently forgotten, is to produce reactive power (Mvar). The discussion on generators will be limited to the fundamentals related to these two functions. More details related to the dynamic performance of generators will be discussed in Module 6. The mechanical structure of generators is out of the scope of this material.

A simplified turbine-generator-exciter system is shown in Figure 2-1. The turbine, or the prime mover, controls the active power generation. For instance, by increasing the valve opening of a steam turbine, more active power can be generated and vice versa. The exciter, represented as an adjustable DC voltage source, controls the field current that controls the internal generated voltage source, \bar{E}_f . Therefore, the generator terminal voltage, \bar{V} , is controlled.

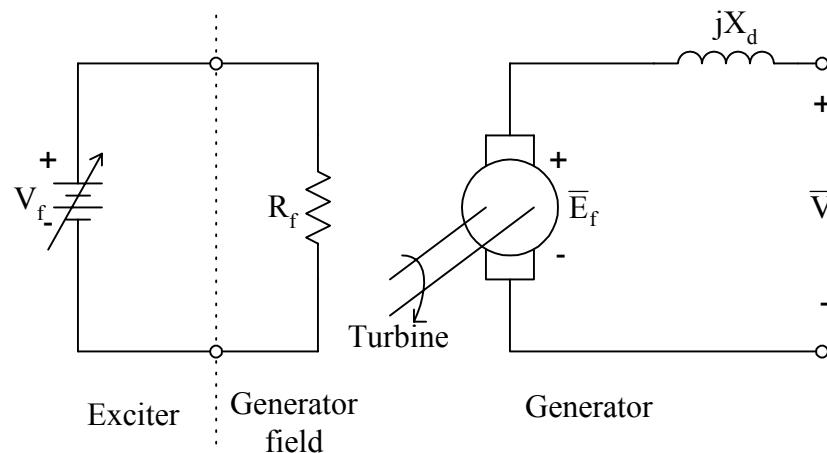

Fig. 2-1. An electrical representation of a simplified turbine-generator-exciter.

The steady-state equivalent circuit of a synchronous generator can be drawn as an internal voltage source and its (direct-axis) synchronous reactance in series as shown in Figure 2-2. The system is represented with an infinite bus, which holds a constant voltage. The generator terminal voltage, or system voltage, is usually chosen as the reference, therefore, a zero degree

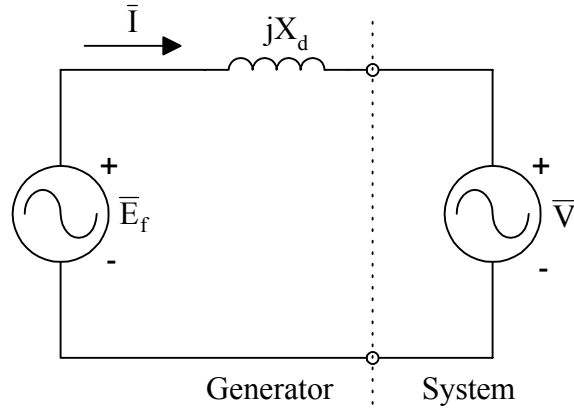

Fig. 2-2. A per phase steady-state equivalent circuit of a synchronous generator and the system.

angle. Then, the generator internal voltage can be obtained

$$\bar{E}_f = \bar{I}(jX_d) + \bar{V} = jX_d\bar{I} + \bar{V} = E_f \angle \delta,$$

where the angle δ is called power angle. A graphical representation of these quantities can be useful and is shown in Figure 2-3.

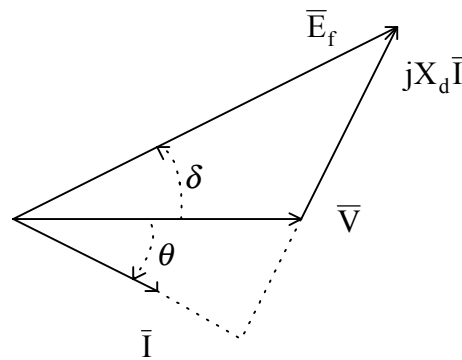

Fig. 2-3. Phasor diagram of \bar{E}_f , \bar{V} , and \bar{I} .

The per phase analysis of the complex power injected to the system can be calculated by

$$\bar{S} = \bar{V}\bar{I}^* = \bar{V} \left[\frac{\bar{E}_f - \bar{V}}{jX_d} \right]^* = V \left[\frac{E_f \angle \delta - V}{X_d \angle 90^\circ} \right]^* = \frac{VE_f}{X_d} \sin \delta + j \left[\frac{VE_f}{X_d} \cos \delta - \frac{V^2}{X_d} \right] = P + jQ.$$

Figure 2-4 shows the active power and reactive power versus the power angle. The maximum value of the active power, P_{\max} , is referred to as the steady-state stability limit and can be calculated as

$$P_{\max} = \frac{VE_f}{X_d}$$

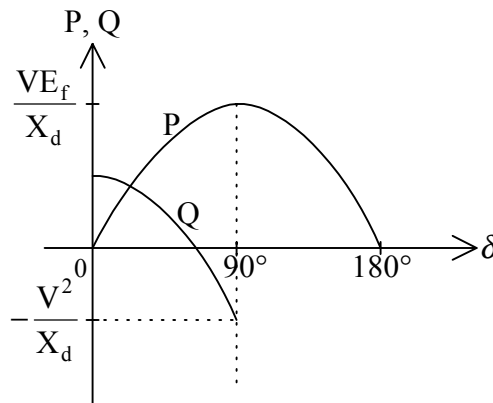

Fig. 2-4. Generator P and Q versus δ .

This maximum power occurs at power angle $\delta = 90^\circ$. It is worth mentioning that when the active power increases, the power angle increases. However, at P_{\max} the power angle is 90° , the angle can not be increased any further, since the generator can not maintain synchronism with the rest of the system.

Example 2-1: A generator has the following data:

$$S_{3\phi,\text{rated}} = 250\text{MVA}, \quad V_{L,\text{rated}} = 13.8\text{kV}, \quad \text{pf}_{\text{rated}} = 0.85(\text{lagging}), \quad X_d = 1.2\text{pu},$$

$$P_{3\phi,\text{rated}} = 212.5\text{MW}, \quad Q_{\max} = 132\text{Mvar}, \quad Q_{\min} = -100\text{Mvar}.$$

- (1) Find P, Q, E_f and δ in per unit when operated at rated terminal conditions. Set 250MVA as the power base.
- (2) If the active power is reduced by 15%, re-evaluate P, Q, E_f and δ .
- (3) If the exciter is adjusted to reduce E_f by 5.56%, re-evaluate P, Q, E_f and δ .

Solution:

- (1) The complex power at rated conditions can be obtained from its rated MVA and rated power factor, namely,

$$\bar{S} = S_{3\phi,\text{rated}} \angle \cos^{-1}(\text{pf}_{\text{rated}}) = 250 \angle \cos^{-1}(0.85) = 250 \angle 31.8^\circ = 212.5 + j132 \text{ MVA}$$

Its per unit value is

$$\bar{S}_{\text{pu}} = \frac{\bar{S}}{S_{\text{Base},3\phi}} = 0.85 + j0.527 \text{ pu}$$

Therefore,

$$P = 0.85 \text{ pu}$$

and

$$Q = 0.527 \text{ pu}$$

To calculate the E_f and δ :

Since the generator is operated at rated conditions, the current in per unit is

$$\bar{I} = 1 \angle -\cos^{-1}(\text{pf}_{\text{rated}}) = 1 \angle -31.8^\circ \text{ pu}$$

$$\bar{E}_f = (j1.2)(1 \angle -31.8^\circ) + 1 \angle 0^\circ = 1.6323 + j1.01987 = 1.925 \angle 32^\circ \text{ pu}$$

Therefore,

$$E_f = 1.925 \text{ pu}$$

and

$$\delta = 32^\circ$$

This is the base case for the following parts (2) and (3).

(2) The active power reduced by 15% of the base case,

$$P = (1 - 0.15) \times (0.85) = 0.7225 \text{ pu}$$

Assuming the change on the active power does not affect the E_f ,

$$E_f = 1.925 \text{ pu}$$

Then, the power angle can be calculated by

$$\delta = \sin^{-1} \left(\frac{PX_d}{E_f V} \right) = \sin^{-1} \left[\frac{(0.7225)(1.2)}{(1.925)(1)} \right] = 26.8^\circ$$

The corresponding reactive power can be calculated,

$$Q = \frac{(1.925) \times 1}{1.2} \cos(26.8^\circ) - \frac{1^2}{1.2} = 0.599 \text{ pu}$$

(3) The E_f is reduced by 5.56% from the base case,

$$E_f = (1 - 0.0556) \times (1.925) = 1.818 \text{ pu}$$

Assuming the adjustment on excitation active power does not affect the active power generation,

$$P = 0.85 \text{ pu}$$

The power angle can be calculated as

$$\delta = \sin^{-1} \left[\frac{(0.85)(1.2)}{(1.818)(1)} \right] = 34.1^\circ$$

The corresponding reactive power can be calculated,

$$Q = \frac{(1.818) \times 1}{1.2} \cos(34.1^\circ) - \frac{1^2}{1.2} = 0.421 \text{ pu}$$

◆

Table 2-1 tabulates the results from Example 2-1 for a comparison purpose. A decrease of 15% on active power generation, the power angle is decreased by 14%. A very small decrease (-5.56%) on the internal generated voltage, it causes a significant decrease (-20%) on generator reactive power production.

Table 2-1: Comparison of P, Q, E_f and δ obtained in Example 2-1.

Case #	P		Q		E_f		δ	
	pu	%	pu	%	pu	%	Degrees	%
1	0.85		0.527		1.925		32	
2	0.7225	-15%	0.599	+14%	1.925		26.8	-14%
3	0.85		0.421	-20%	1.818	-5.56%	34.1	+6.6%

Another important steady-state limitation on generators is its reactive limits. A typical generator reactive capability curve is shown in Figure 2-5. At each MW output, there are two corresponding reactive limits, one overexcited and the other one underexcited. As one can see from the curve, the continuous reactive power output capability is limited by the stator heating limit (armature current limit), the rotor heating limit (field current limit), and the stator end turn (end region) heating limit. The generator reactive capability will affect generators' ability to regulate the system voltage under normal and contingency conditions, and consequently, the performance of the power systems.

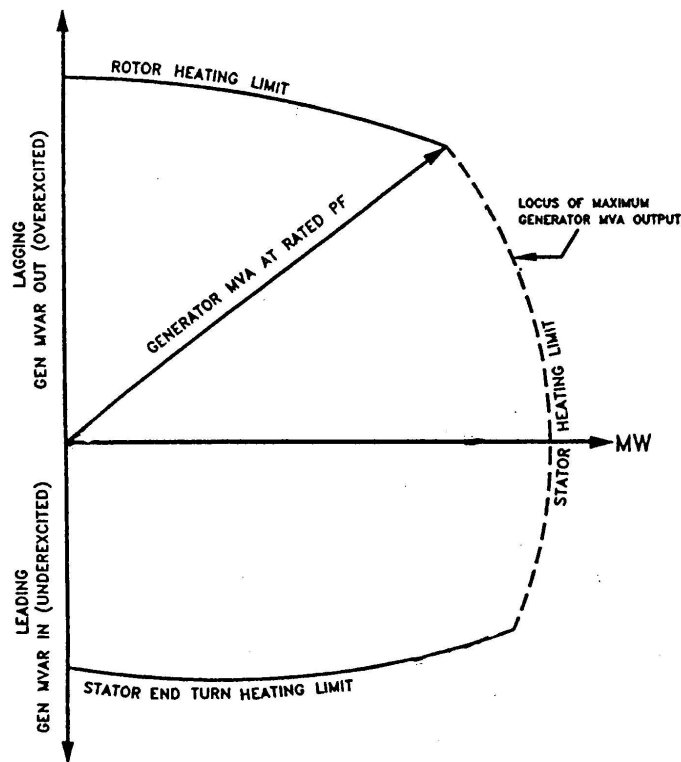

Fig. 2-5. A typical generator reactive capability curve.

To summarize the discussions on synchronous generators:

- 1) The amount of active power (MW) generated by a synchronous generator is a function of δ , and δ is controlled by the mechanical drive on the rotor.
- 2) The amount of reactive power (Mvar) generated by a synchronous generator is a function of E_f , and E_f is controlled by the electrical excitation on the rotor.

Transmission Lines

The equipment connecting the generated electrical energy from the generation to the Distribution system is the transmission line. A transmission system is a massive interconnected network consists of mainly AC transmission lines with various high/extra high voltage levels. The main advantage of having higher voltage in transmission system is to reduce the losses in the grid.

Electrical energy is transported from generating stations to their loads through overhead lines and cables. Overhead transmission lines are used for long distances in open county and rural areas, while cables are used for underground transmission in urban areas and for underwater crossings. Because the cost for cables is much more expensive than the overhead lines, cables are used in special situations where overhead lines can not be used. Since the majority of transmission lines are overhead lines, the discussion is limited to overhead lines only.

Before discussing the model for transmission lines, some related terms need to be clearly defined. The parameters for modeling of overhead transmission lines are:

- (1) Series (line) Resistance (R) – The resistance of the conductor.
- (2) Series (line) inductance (L) – The line inductance depends on the partial flux linkages within the conductor cross-section and external flux linkages.
- (3) Shunt capacitance (C) – The potential difference between the conductors of a transmission line causes the conductors to be charged.

Then, the series (line) impedance of the transmission line can be expressed as

$$\bar{Z} = R + jX_L = R + j\omega L \quad \Omega,$$

and the shunt admittance of the transmission line can be expressed as

$$\bar{Y} = jB_c = j\omega C \quad \text{Siemen.}$$

The characteristic impedance of a transmission line is defined as

$$\bar{Z}_c = \sqrt{\frac{\bar{Z}}{\bar{Y}}} = \sqrt{\frac{R + j\omega L}{j\omega C}} \quad \Omega.$$

If the resistance of the transmission line is neglected, the characteristic impedance can be simplified as

$$\bar{Z}_c = Z_c = \sqrt{\frac{j\omega L}{j\omega C}} = \sqrt{\frac{L}{C}} \Omega,$$

which is a real number in this case. It is commonly referred to as the surge impedance. The power delivered by a transmission line when it is terminated by its surge impedance is known as the surge impedance load (SIL),

$$\text{SIL} = \frac{V_{L,\text{rated}}^2}{Z_c} \text{ MW.}$$

When the loading of a transmission line is heavier than its SIL, the voltage will be decreasing along the line. This implies that the reactive power generated from the line charging is less than the reactive power consumption of the line impedance. Therefore, the transmission line acts as an inductor. When the loading of the line is light, less than its SIL, the line reactive charging is greater than the line reactive consumption. At light loading conditions, a transmission line acts like a capacitor, and the voltage along the line will be increasing. The voltage profile along the line is the same, as shown in Figure 2-6, when the loading of the line is at its SIL.

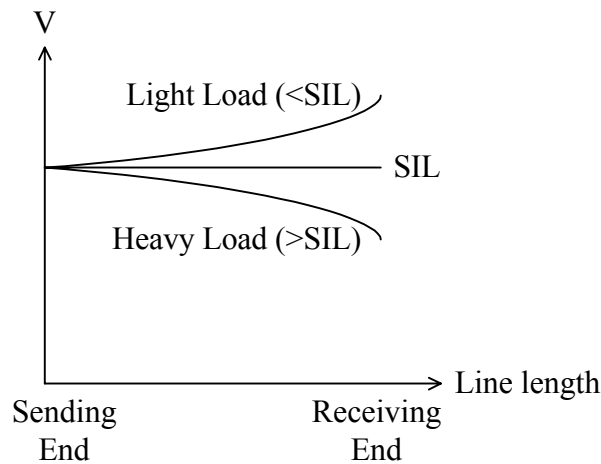

Fig. 2-6. Voltage profiles with various loading conditions on the transmission line.

The model commonly used for AC overhead transmission lines is called Pi (π) network and is shown in Figure 2-7. Please note that the shunt admittance has been even divided into two shunt elements connecting to both ends of a pi equivalent network. By KVL:

$$\bar{V}_s = \bar{Z} \left(\bar{I}_r + \frac{\bar{Y}}{2} \bar{V}_r \right) + \bar{V}_r = \left(1 + \frac{\bar{Z}\bar{Y}}{2} \right) \bar{V}_r + \bar{Z}\bar{I}_r,$$

By KCL:

$$\bar{I}_s = \frac{\bar{Y}}{2} \bar{V}_s + \left(\bar{I}_r + \frac{\bar{Y}}{2} \bar{V}_r \right) = \left(\bar{Y} + \frac{\bar{Z}\bar{Y}^2}{4} \right) \bar{V}_r + \left(1 + \frac{\bar{Z}\bar{Y}}{2} \right) \bar{I}_r,$$

where

\bar{V}_s = the sending end voltage,

\bar{I}_s = the sending end current,

\bar{V}_r = the receiving end voltage,

and

\bar{I}_r = the receiving end current.

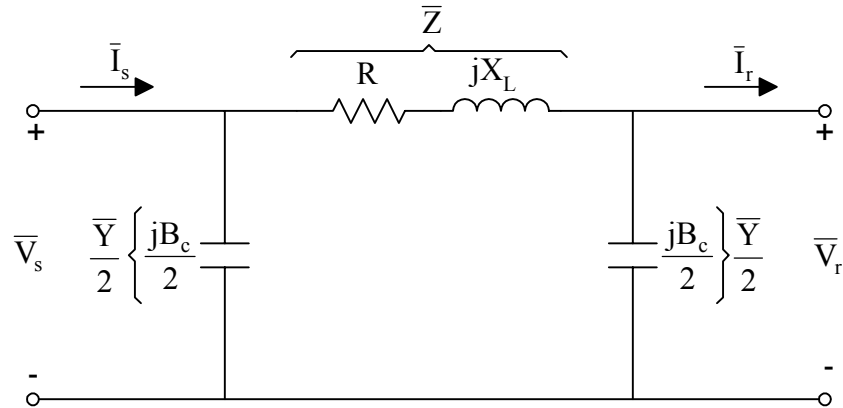

Fig. 2-7. A pi network for a transmission line model.

Recall the transmission (\bar{A} , \bar{B} , \bar{C} and \bar{D}) parameters of a two-port network. The two equations can be re-written in a matrix notation,

$$\begin{bmatrix} \bar{V}_s \\ \bar{I}_s \end{bmatrix} = \begin{bmatrix} 1 + \frac{\bar{Z}\bar{Y}}{2} & \bar{Z} \\ \bar{Y} + \frac{\bar{Z}\bar{Y}^2}{4} & 1 + \frac{\bar{Z}\bar{Y}}{2} \end{bmatrix} \begin{bmatrix} \bar{V}_r \\ \bar{I}_r \end{bmatrix} = \begin{bmatrix} \bar{A} & \bar{B} \\ \bar{C} & \bar{D} \end{bmatrix} \begin{bmatrix} \bar{V}_r \\ \bar{I}_r \end{bmatrix},$$

where

$$\bar{A} = 1 + \frac{\bar{Z}\bar{Y}}{2} = \bar{D},$$

$$\bar{B} = \bar{Z},$$

and

$$\bar{C} = \bar{Y} + \frac{\bar{Z}\bar{Y}^2}{4}.$$

Example 2-2: A transmission line has a series impedance and a shunt admittance as follows $\bar{Z} = 8.8 + j46.54 \, \Omega$ and $\bar{Y} = j0.3524 \, \text{mS}$, find:

- (1) The characteristic impedance of the transmission line.

- (2) The model of the transmission line by a pi equivalent network with its actual impedance/admittance values.
- (3) If $S_{3\phi, \text{Base}} = 100\text{MVA}$ and $V_{L, \text{Base}} = 230\text{kV}$, re-evaluate part (2) with per unit values and calculate transmission parameters, \bar{A} , \bar{B} , \bar{C} and \bar{D} in per unit values.

Solution:

$$(1) \bar{Z}_c = \sqrt{\frac{8.8 + j46.54}{j0.3524 \times 10^{-3}}} = \sqrt{\frac{47.3645 \angle 79.3^\circ}{0.0003524 \angle 90^\circ}} = \sqrt{134405.98} \angle \left(\frac{-10.7^\circ}{2} \right) = 366.6 \angle -5.35^\circ \Omega$$

If neglecting the series resistance,

$$Z_c = \sqrt{\frac{46.54}{0.3524 \times 10^{-3}}} = 363.4 \Omega$$

$$(2) \bar{Z} = 8.8 + j46.54 \Omega$$

$$\frac{\bar{Y}}{2} = \frac{j0.0003524}{2} = j0.0001762 \text{ S}$$

The transmission line model is shown in Figure 2-8.

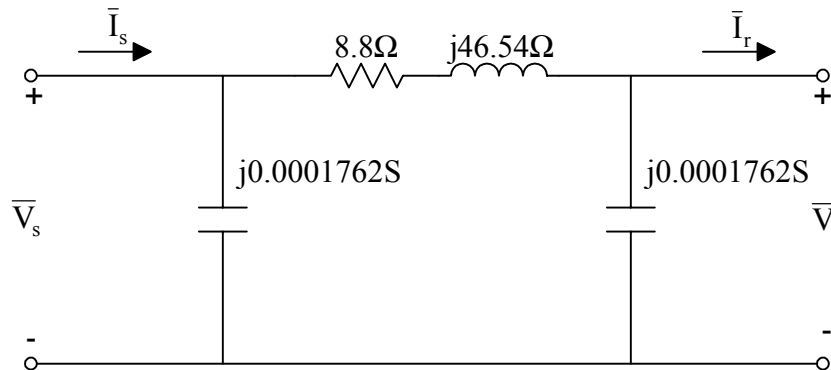

Fig. 2-8. The pi equivalent model in actual values for the given transmission line.

$$(3) Z_{\text{Base}} = \frac{V_{L, \text{Base}}^2}{S_{\text{Base}, 3\phi}} = \frac{230^2}{100} = 529 \Omega$$

$$\bar{Z}_{\text{pu}} = \frac{8.8 + j46.54}{529} = 0.016635 + j0.087977 \text{ pu}$$

$$\left(\frac{\bar{Y}}{2} \right)_{\text{pu}} = \frac{j0.0001762}{1/529} = j0.09321 \text{ pu} \quad (\text{hint: } Y_{\text{Base}} = 1/Z_{\text{Base}})$$

The transmission line model in per unit is shown in Figure 2-9.

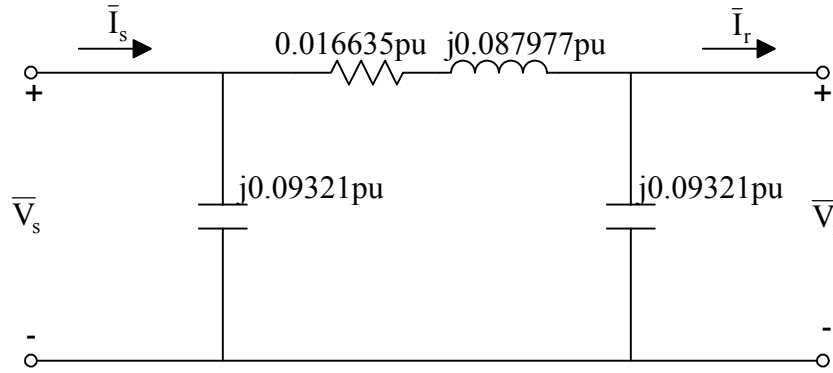

Fig. 2-9. The pi equivalent model in per unit values for the given transmission line.

For the transmission parameters, \bar{A} , \bar{B} , \bar{C} and \bar{D} :

$$\bar{A} = \bar{D} = 1 + (0.016635 + j0.087977)(j0.09321) = 0.9917834 \angle 0.084^\circ \text{ pu}$$

$$\bar{B} = 0.016635 + j0.087977 = 0.0895358 \angle 79.95^\circ \text{ pu}$$

$$\bar{C} = 2 \times (j0.09321) + (0.0895358 \angle 79.95^\circ)(j0.09321)^2 = 0.185654 \angle 90.04^\circ \text{ pu} \quad \blacklozenge$$

Transformers

The main functions of transformers are stepping up voltages from the lower generation levels to the higher transmission voltage levels and stepping down voltages from the higher transmission voltage levels to the lower distribution voltage levels. The main advantage of having higher voltage in transmission system is to reduce the losses in the grid. Since transformers operate at constant power, when the voltage is higher, then the current has a lower value. Therefore, the losses, a function of the current square, will be lower at a higher voltage.

The output power of an ideal two winding transformer equals the input power while having two different voltage levels on its input and output terminals, namely,

$$\bar{S}_1 = \bar{S}_2.$$

The equivalent circuit of an ideal transformer is shown in Figure 2-10. This is assumed to be a generator step-up transformer (GSU) that will step-up the voltage at the primary side (or low side) from a lower level to a higher voltage at the secondary side (high side). It is commonly assumed that power flows from the primary side to the secondary side of transformers. The primary/secondary voltages and currents have the following relationship:

$$\bar{E}_1 \bar{I}_1 = \bar{E}_2 \bar{I}_2,$$

$$\frac{\bar{E}_1}{N_1} = \frac{\bar{E}_2}{N_2},$$

and

$$N_1 \bar{I}_1 = N_2 \bar{I}_2,$$

where

\bar{E}_1 = primary voltage,

\bar{I}_1 = primary current,

N_1 = number of primary turns,

\bar{E}_2 = secondary voltage,

\bar{I}_2 = secondary current,

and

N_2 = number of secondary turns.

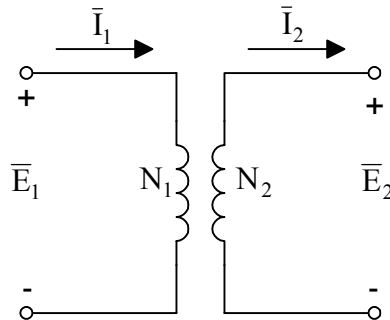

Fig. 2-10. A representation of an ideal two winding transformer.

To have a more accurate model for transformers, core losses and copper losses need to be considered. The core losses are commonly assumed to be a constant as load goes from no-load to full load, while the copper losses vary as the square of the load (current). Therefore, the equivalent circuit of a transformer can be expanded as shown in Figure 2-11.

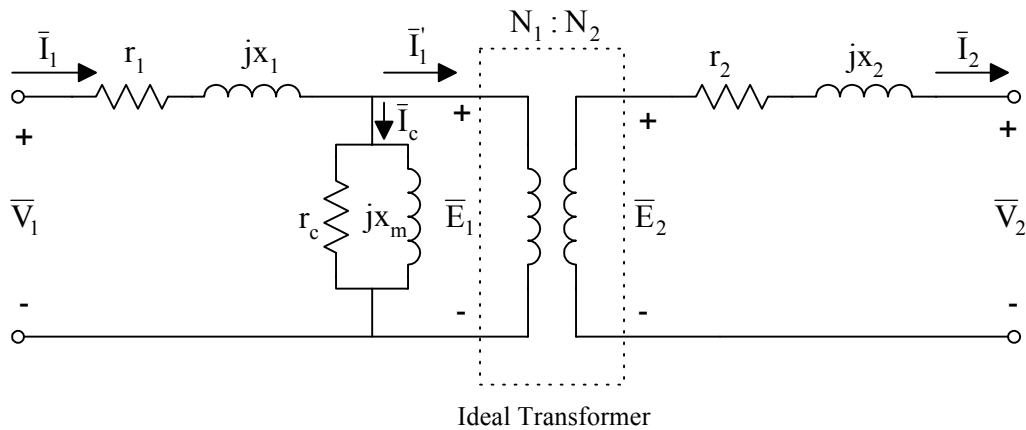

Fig. 2-11. An equivalent circuit of a two winding transformer.

By KVL,

$$\bar{V}_1 = \bar{I}_1(r_1 + jx_1) + \bar{E}_1,$$

and

$$\bar{V}_2 = \bar{E}_2 - \bar{I}_2(r_2 + jx_2).$$

By KCL,

$$\bar{I}'_1 = \bar{I}_1 - \bar{I}_c.$$

where

r_1 = primary winding resistance,

x_1 = primary leakage reactance,

\bar{V}_1 = applied primary voltage,

\bar{I}_c = exciting current,

r_c = resistance representing core losses,

x_m = reactance representing magnetizing current,

$n = \frac{N_1}{N_2}$, turn ratio, rated primary voltage/rated secondary voltage,

r_2 = secondary winding resistance,

x_2 = secondary leakage reactance,

and

\bar{V}_2 = applied secondary voltage.

The exciting current is small as compared to rated current. Since r_c and x_m are very large in comparison to other ohmic values, they are generally ignored in circuit calculation. Under this condition, if secondary values are referred to the primary side, the equivalent circuit can be simplified and redrawn as shown in Figure 2-12. The equivalent resistance and reactance can be calculated as follows

$$r_{eq} = r_1 + n^2 r_2,$$

and

$$x_{eq} = x_1 + n^2 x_2.$$

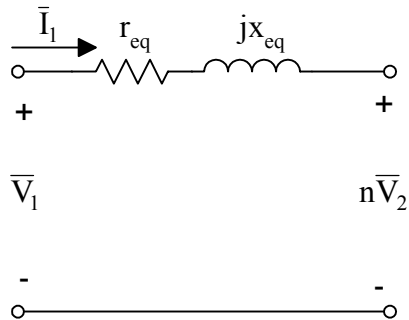

Fig. 2-12. The transformer equivalent circuit with impedances referred to primary.

Similarly, one can refer all impedances to the secondary side. (Relations refer from primary to secondary in inverse order)

Two quantities that help describe the operation of a transformer are its voltage regulation and efficiency. Voltage regulation is defined as the change in the voltage from no load to full load as a percentage of the full-load voltage. Efficiency is defined as power output divided by power input and is usually given as a percent quantity as well. The voltage regulation (VR) and efficiency (η) can be expressed as

$$VR = \frac{V_{nl} - V_{fl}}{V_{fl}} \times 100\%,$$

and

$$\eta = \frac{P_{out}}{P_{in}} \times 100\% = \frac{P_{out}}{P_{out} + P_{losses}} \times 100\%,$$

where

V_{fl} = full-load voltage,

V_{nl} = no-load voltage,

P_{out} = output power,

P_{in} = input power,

and

P_{losses} = power losses including core losses and copper losses.

Sometimes the impedances of a transformer are not given. Instead, the results from a short circuit test and open circuit test are given. However, the details on the short circuit and open circuit tests are out of the scope of this material. The following example should be sufficient for readers to review these tests and to understand the material presented so far in this section.

Example 2-3: Short circuit and open circuit tests in the usual way are conducted on a 75 kVA 7600:240 volt single-phase transformer. The data are listed below:

Type of Test	Volts	Amperes	Watts
S-C	380 (V_{S-C})	9.87 (I_{S-C})	750 (P_{S-C})
O-C	240 (V_{O-C})	11.1 (I_{O-C})	600 (P_{O-C})

Find:

- (1) The transformer equivalent circuit with all quantities referred to the high side.
- (2) The exciting current taken by the transformer when energized with rated voltage on the high side of the transformer.
- (3) The voltage regulation and efficiency of the transformer when delivering rated kVA at 0.8 power factor lagging at rated voltage.
- (4) Express $r_{eq} + jx_{eq}$ in per unit on the transformer rating.

Solution:

(1) The short circuit test is commonly performed on the high side of the transformer. The equivalent winding impedance can be calculated.

$$r_{eq} = \frac{P_{S-C}}{I_{S-C}^2} = \frac{750}{9.87^2} = 7.7\Omega$$

$$Z_{eq} = \frac{V_{S-C}}{I_{S-C}} = \frac{380}{9.87} = 38.5\Omega$$

$$x_{eq} = \sqrt{Z_{eq}^2 - r_{eq}^2} = \sqrt{38.5^2 - 7.7^2} = 37.72\Omega$$

The open circuit test is commonly performed on the low side of the transformer. The conversion from the low side to the high side is necessary to calculate the r_c and x_m . The turn ratio

$$n = \frac{7600}{240} = 31.66667$$

Since

$$P_{O-C} = \frac{V_{O-C}^2}{\frac{r_c}{n^2}}$$

Therefore,

$$r_c = \frac{n^2 V_{O-C}^2}{P_{O-C}} = \frac{(31.66667)^2 240^2}{600} = 96267\Omega$$

Then,

$$n^2 \left(\frac{1}{r_c} + \frac{1}{jx_m} \right) = \frac{I_{O-C}}{V_{O-C}}$$

$$x_m = \frac{n^2}{\sqrt{\left(\frac{I_{O-C}}{V_{O-C}} \right)^2 - \left(\frac{n^2}{r_c} \right)^2}} = \frac{(31.66667)^2}{\sqrt{\left(\frac{11.1}{240} \right)^2 - \left(\frac{31.66667^2}{96267} \right)^2}} = 22253\Omega$$

The equivalent circuit for the given transformer with all impedances referred to the high side is shown in Figure 2-13.

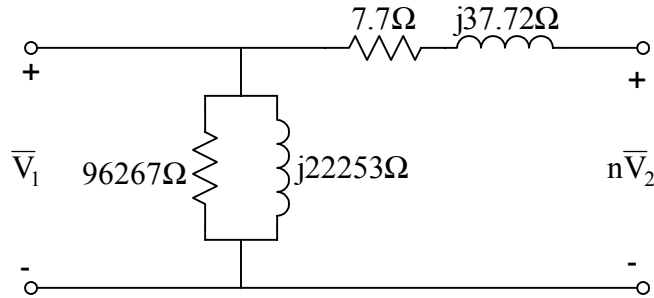

Fig. 2-13. The equivalent circuit of the given transformer.

$$(2) I_c = \frac{7600}{\frac{1}{\sqrt{\left(\frac{1}{96267}\right)^2 + \left(\frac{1}{22253}\right)^2}}} = 0.35 \text{ amps}$$

or,

$$I_c = \frac{I_{O-C}}{n} = \frac{11.1}{31.66667} = 0.35 \text{ amps}$$

(3) Figure 2-13 can be used for voltage regulation calculation.

The current at the rated kVA at 0.8 power factor lagging at rated voltage is

$$\bar{I}_{\text{rated}} = \frac{75000}{7600} \angle -\cos^{-1}(0.8) = 9.868 \angle -36.87^\circ \text{ amps}$$

Assuming the voltage at the terminals on the right hand side is 7600 volts, the voltage at the left hand side can be calculated.

$$\bar{V}_1 = 7600 \angle 0^\circ + (9.868 \angle -36.87^\circ)(7.7 + j37.72) = 7884.1 + j252.15 = 7888.13 \angle 1.83^\circ \text{ V}$$

The voltage regulation can be calculated as

$$\text{VR} = \frac{7888.13 \times \frac{240}{7600} - 240}{240} \times 100\% = 3.79\%$$

The power output is the product of the rated kVA and the load power factor, namely,

$$P_{\text{out}} = 75 \times 0.8 = 60 \text{ kW}$$

The efficiency is

$$\eta = \frac{60000}{60000 + 750 + 600} \times 100\% = 97.8\%$$

$$(4) Z_{\text{Base}} = \frac{7600^2}{75000} = 770.1 \Omega$$

$$r_{eq} = \frac{7.7}{770.1} = 0.01 \text{ pu}$$

$$x_{eq} = \frac{37.72}{770.1} = 0.049 \text{ pu}$$

◆

There is another type of transformers in power systems, three winding transformers. A typical equivalent circuit for a three winding transformer is shown in Figure 2-14. Three short circuit tests are made to measure its impedances. The method of testing is given by Table 2-2 below.

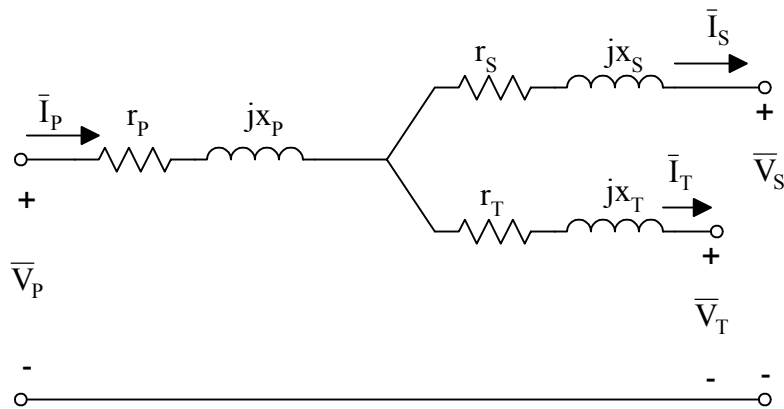

Fig. 2-14. An equivalent circuit of a three winding transformer in per unit values.

Table 2-2. Method of testing for a three winding transformer.

Winding Energized	Winding Short-circuited	Winding Open	Impedance Measured
Primary (P)	Secondary (S)	Tertiary (T)	\bar{Z}_{PS}
Primary (P)	Tertiary (T)	Secondary (S)	\bar{Z}_{PT}
Secondary (S)	Tertiary (T)	Primary (P)	\bar{Z}_{ST}

Three impedances are obtained from the three short circuit tests. To calculate the three individual winding impedances, \bar{Z}_P , \bar{Z}_S , and \bar{Z}_T , the following three equations can be used.

$$\bar{Z}_P = \frac{1}{2}(\bar{Z}_{PS} + \bar{Z}_{PT} - \bar{Z}_{ST}),$$

$$\bar{Z}_S = \frac{1}{2}(\bar{Z}_{PS} + \bar{Z}_{ST} - \bar{Z}_{PT}),$$

and

$$\bar{Z}_T = \frac{1}{2}(\bar{Z}_{PT} + \bar{Z}_{ST} - \bar{Z}_{PS}).$$

It is worth mentioning that although the real and imaginary parts of the three measured impedances (\bar{Z}_{PS} , \bar{Z}_{ST} , and \bar{Z}_{PT}) are all positive, but some of the real and imaginary parts of the individual winding impedances (\bar{Z}_P , \bar{Z}_S , and \bar{Z}_T) may have negative values.

Example 2-4: Three impedances are measured from three short circuit tests:

$$\bar{Z}_{PS} = 0.015 + j0.07 \text{ pu}; \bar{Z}_{ST} = 0.05333 + j0.02446 \text{ pu}; \bar{Z}_{PT} = 0.025 + j0.08507 \text{ pu}$$

Calculate three individual winding impedances, \bar{Z}_P , \bar{Z}_S , and \bar{Z}_T .

Solution:

$$\bar{Z}_P = \frac{1}{2} [(0.015 + 0.025 - 0.05333) + j(0.07 + 0.08507 - 0.02446)] = -0.006665 + j0.065305$$

$$\bar{Z}_S = \frac{1}{2} [(0.015 + 0.05333 - 0.025) + j(0.07 + 0.02446 - 0.08507)] = 0.021665 + j0.004695$$

$$\bar{Z}_T = \frac{1}{2} [(0.05333 + 0.025 - 0.015) + j(0.02446 + 0.08507 - 0.07)] = 0.031665 + j0.019765$$

◆

The discussions so far are for single-phase transformers. Three single-phase transformers (usually identical) can be used for three-phase applications, either in a delta or wye configuration. The properties discussed in Module #1 for delta and wye configurations can be applied for transformers. Also, some transformers are built as three-phase transformers.

Example 2-5: Given a system as shown below:

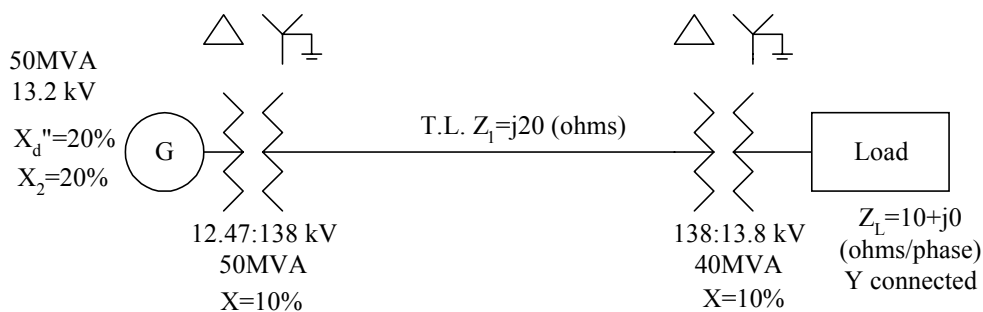

Compute three-phase (3 ϕ) fault currents in kA at the load, transmission line and generator terminal.

Select $S_{\text{Base},3\phi} = 50\text{MVA}$ and $V_{\text{Base},L} = 138\text{kV}$ at the transmission line.

Solution:

Use per phase analysis for this problem:

At transmission line section,

$$S_{\text{Base}} = \frac{S_{\text{Base},3\phi}}{3} = \frac{50}{3} = 16.66667 \text{ MVA}$$

$$V_{\text{Base}} = \frac{V_{\text{Base,L}}}{\sqrt{3}} = \frac{138}{\sqrt{3}} = 79.6743 \text{ kV}$$

$$I_{\text{Base}} = \frac{16.66667}{79.6743} = 0.209185 \text{ kA}$$

$$Z_{\text{Base}} = \frac{79.6743}{0.209185} = 380.88 \text{ } \Omega$$

Similarly, the base values at the generator section and load section can be obtained and tabulated in Table 2-3.

Table 2-3. Base values at different sections of the given system.

Location	S_{Base} (MVA)	V_{Base} (kV)	I_{Base} (kA)	Z_{Base} (Ω)
Generator	16.66667	7.1996	2.31494	3.11
Transmission Line	16.66667	79.6743	0.209185	380.88
Load	16.66667	7.96743	2.09185	3.8088

$$X_{\text{G}} = (0.2) \left(\frac{13.2}{12.47} \right)^2 = 0.2241016 \text{ pu}$$

$$X_{\text{T1}} = 0.1 \text{ pu}$$

$$X_{\text{T2}} = (0.1) \left(\frac{50}{40} \right) = 0.125 \text{ pu}$$

$$X_{\text{TL}} = \frac{20}{380.88} = 0.05251 \text{ pu}$$

The generator voltage at pre-fault is 13.2 kV, and its per unit value is

$$\bar{V}_{\text{G}} = \frac{13.2 \angle 0^\circ}{12.47} = 1.05854 \angle 0^\circ \text{ pu}$$

The equivalent circuit for the given system with a three-phase fault at load terminals is shown in Figure 2-15.

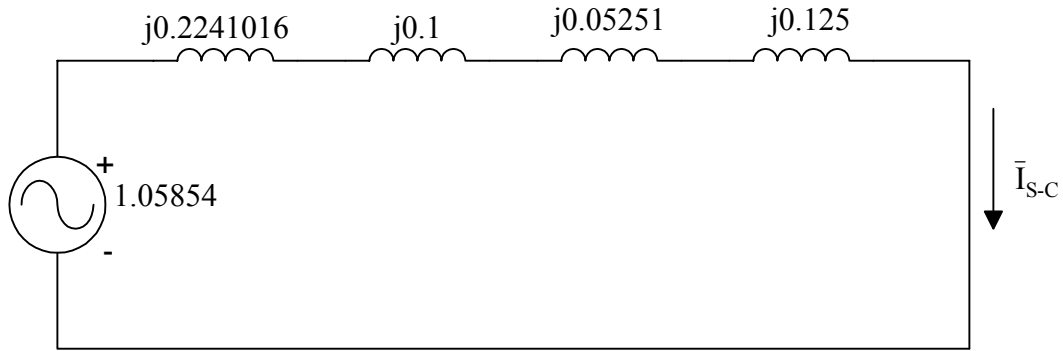

Fig. 2-15. The equivalent circuit in per unit values for the given system.

$$\bar{I}_{S-C} = \frac{1.05854}{j(0.2241016 + 0.1 + 0.05251 + 0.125)} = -j2.11028 \text{ pu}$$

The three-phase fault current at the load terminals:

$$\bar{I}_{S-C, \text{load}} = (-j2.11028)(2.09185) = -j4.4143892 \text{ kA}$$

The three-phase fault current on the transmission line:

$$\bar{I}_{S-C, \text{TL}} = (-j2.11028)(0.209185) = -j0.44143892 \text{ kA}$$

The three-phase fault current at the generator terminals:

$$\bar{I}_{S-C, \text{G}} = (-j2.11028)(2.31494) = -j4.8851716 \text{ kA}$$

◆