

## Design of High-Purity Water Systems

### Course Content

#### Introduction

Water is an exceptionally aggressive *solvent* that attacks most of the substances it contacts. More substances dissolve in water than any other solvent. Most of the known elements can be found dissolved in water, some in high concentrations and others only in trace amounts. As water moves through the natural hydrologic cycle, it dissolves substances it contacts. Contaminants include atmospheric gases (oxygen, nitrogen, and carbon dioxide), dissolved minerals and organic substances, and suspended colloidal matter. Water also provides an ideal environment for the growth of bacteria and other microorganisms if the necessary nutrients and conditions for growth exist.

Depending on the type and concentration of contaminants, most natural waters are not suitable for potable use much less for most research and industrial applications. Most all municipalities and other purveyors of potable water provide some level of water treatment to make the water suitable for consumption. The U.S. Environmental Protection Agency has established legally enforceable National Primary Drinking Water Regulations (NPDWR) for public water systems. These regulations are published on the U.S. EPA website ([www.epa.gov](http://www.epa.gov)).

Most high-purity water systems use potable water as a feed water source and provide additional treatment to remove residual contaminants to meet the water quality specifications for the given application. Reagent grade water specifications have been established by such organizations as the College of American Pathologists (CAP), National Committee for Clinical Laboratory Standards (NCCLS), and the American Society for Testing and Materials (ASTM).

The United States Pharmacopoeia (USP) establishes specifications for *compendial* water used in the manufacturing of drug products. The two major *compendial* water types are USP purified water and USP water for injection.

The ASTM and Semiconductor Equipment and Materials International (SEMI) have established specifications for electronics grade water used to manufacture microelectronic devices. The Association for the Advancement of Medical Instrumentation (AAMI) has established water quality standards for water used in hemodialysis applications. Many industries have established unique water quality standards specific for their use.

## Unique Properties of Water

The strong *covalent* chemical bond that combines two hydrogen atoms with an oxygen atom to form a water molecule is much stronger than the *ionic* chemical bonds of most other substances. The distribution of electrons in the water molecule causes the hydrogen atoms to bond with the oxygen atom at an unusual bond angle of about 105 degrees. This results in a very *polar* molecule with an electronegative region at the oxygen atom and electropositive regions at the hydrogen atoms.

The polar nature of the water molecule causes it to become electrostatically attractive to other water molecules as well as other ions in solution and contact surfaces with electrostatic sites. This bridging phenomenon with other water molecules is called *hydrogen bonding*. Although the hydrogen bond is only about one tenth the strength of the covalent bond, it is responsible for most of the unique properties of water. These properties include high freezing and boiling point temperatures, high heat capacity and high heats of fusion and evaporation, high surface tension, and the exceptional ability to attack and dissolve many substances.

## Units of Concentration

Since the water engineer most often deals with very dilute concentrations of contaminants, it is convenient to express the concentration of contaminants in terms of weight per unit volume (mg/l). For very dilute solutions, mg/l is approximately equivalent to parts per million (PPM). Since one liter of water weighs approximately 1000 grams or 1,000,000 milligrams, PPM is a weight per unit weight expression. Therefore, potable water with a total dissolved solids concentration of 250 mg/l (250 PPM) can be expressed as 0.025% by weight dissolved solids.

$$(250 / 1,000,000) \times (100) = 0.025\%$$

Other concentration units useful in high purity water are micrograms per liter ( $\mu\text{g/l}$ ) and parts per billion (PPB). Since one liter of water weighs about 1,000,000,000 micrograms, then the units micrograms per liter ( $\mu\text{g/l}$ ) are equivalent to PPB.

Therefore, PPM and PPB are related by a factor of 1,000:

$$\text{PPM} \times 1000 = \text{PPB}$$

## Contaminants in Water

To design a high-purity water system, the specific contaminants in the source water must be identified and measured. The NCCLS classifies water contaminants into six general categories: dissolved solids (inorganics), dissolved

organics, dissolved gases, particulate matter, microorganisms, and endotoxins (bacterial by-products that are toxic in injectable drug products).

### Dissolved Solids

Total dissolved solids (TDS) include all the ionized inorganic salts in solution. Dissolved salts ionize into their respective cations and anions in water and contribute to electrical conductivity. The approximate TDS concentration in water can be determined by measuring the electrical conductivity or resistivity. In pure water, a relatively small number of water molecules ionize into hydrogen and hydroxyl ions; therefore, pure water is a relatively poor conductor of electrical current. The theoretical resistivity of pure water is about 18.2 megohm-cm (18,200,000 ohm-cm). In contrast, most potable waters have resistivities ranging from about 10,000 ohm-cm to 1,000 ohm-cm. The relationships between resistivity, conductivity, and approximate TDS are shown in the following table.

<b>Resistivity</b> (ohm-cm)	<b>Conductivity</b> ( $\mu$ S/cm)	<b>TDS</b> (PPM as NaCl)
1,000	1,000	500
2,000	500	240
3,000	333	160
4,000	250	120
5,000	200	93
10,000	100	46
50,000	20	9
100,000	10	4.6
500,000	2	0.9
1,000,000	1	0.44
5,000,000	0.2	0.067
10,000,000	0.1	0.021
15,000,000	0.067	0.005
18,200,000	0.055	0

Resistivity (megohm-cm) is the reciprocal of conductivity in microSiemens/cm ( $\mu$ S/cm).

Example: If the resistivity of a water sample is 2,500 ohm-cm, what is the conductivity?

$$2,500 \text{ ohm-cm} / 1,000,000 = 0.0025 \text{ megohm-cm}$$

$$1 / 0.0025 = 400 \text{ microSiemens/cm } (\mu\text{S/cm})$$

Common cations (positive charged ions) in potable water include sodium ( $\text{Na}^+$ ), potassium ( $\text{K}^+$ ), calcium ( $\text{Ca}^{++}$ ), magnesium ( $\text{Mg}^{++}$ ), ferrous iron ( $\text{Fe}^{++}$ ), aluminum ( $\text{Al}^{+++}$ ), etc. Trace amounts of heavy metals such as lead, zinc, and copper could also be present. Total hardness includes calcium and magnesium salts; the main concern with hardness is scale formation in hot water heaters, distribution piping, stills, and reverse osmosis membranes. Ion-exchange softening is generally used for hardness removal.

At high pH ranges ( $> 7.0$  pH) and in the presence of oxidizing agents such as dissolved oxygen or chlorine, ferrous iron readily oxidizes to insoluble ferric iron ( $\text{Fe}^{+++}$ ) which can foul ion-exchange resins and RO membranes. Treatment methods for removal of iron include manganese greensand and Pyrolox. Softening can also be effective in some circumstances.

Common anions (negative charged ions) in potable water include chloride ( $\text{Cl}^-$ ), sulfate ( $\text{SO}_4^{--}$ ), nitrate ( $\text{NO}_3^-$ ), carbonate ( $\text{CO}_3^{--}$ ), bicarbonate ( $\text{HCO}_3^-$ ), etc. Total alkalinity includes carbonate, bicarbonate, and hydroxyl ions. If present with hardness cations and some heavy metals, alkalinity can contribute to scale formation.

Silica ( $\text{SiO}_2$ ) is one of the most common elements on earth, and it is very common in natural waters. Silica concentrations in water can create scaling problem in boilers, stills, reverse osmosis membranes, and cooling water systems. Silica is usually present in two forms: ionic silica (reactive) as  $\text{SiO}_2$  complex, and colloidal (non-reactive) particles. Ionic silica is weakly ionized, but it can be removed by ion-exchange, reverse osmosis, or distillation. Colloidal silica is present in sub-micron particles (less than 0.1 microns) and can be removed by ultrafiltration, reverse osmosis, or distillation.

TDS removal is accomplished using such technologies as ion-exchange demineralization, electrodeionization, reverse osmosis, or distillation.

### Dissolved Organics

Dissolved organics in water occur from the natural degradation of vegetation and animal wastes and as pollution from synthetic compounds such as pesticides and other chemicals in industrial discharges. Naturally occurring contaminants include compounds such as tannins and lignins, humic and fulvic acids. These compounds cause color in water and can foul ion-exchange resins and RO membranes. Free chlorine can react with some of these compounds and form trihalomethanes (THM) which are determined to be carcinogenic (cancer causing).

Many synthetic organic compounds are used in industry and agriculture and can be found in natural water from industrial discharges or by leaching and runoff from soils. Many of these compounds have significant health consequences and are regulated by the EPA.

Total organic carbon (TOC) is a direct, quantitative measure of the amount of oxidizable, carbon-based organic matter in water. TOC concentrations in potable water typically range from about 5 to 20 PPM.

*Adsorption* with activated carbon is the most effective means for removing most dissolved organic contaminants. Reverse osmosis is also effective for removing organic compounds larger than about 150 molecular weight (MW) in size; TOC rejections of greater than 95 percent can be achieved with RO membranes. The use of 185 nm ultraviolet is an effective method for further reducing trace dissolved organic contamination in high purity water.

### Dissolved Gases

Dissolved gases include carbon dioxide, oxygen, nitrogen, and hydrogen sulfide. Carbon dioxide ( $\text{CO}_2$ ) is moderately soluble in water and can *absorb* in water from the atmosphere; however, most of the carbon dioxide in natural waters comes from the carbonates dissolved in water. Carbon dioxide reacts with water forming carbonic acid. Carbonic acid weakly ionizes forming bicarbonates and carbonates. The distribution of carbon dioxide, bicarbonates, and carbonates is a function of the pH of the water. Carbon dioxide reduces the pH of water and is responsible for corrosion in water lines and boilers. Although weakly ionized, carbon dioxide can be removed by ion-exchange and de-aeration methods.

The solubility of atmospheric gases in water is directly proportional to the partial pressure of the gas above the solution; this is known as Henry's Law. Accordingly, oxygen and nitrogen gas dissolve in water to saturation levels. Temperature and TDS content can also affect solubility. Nitrogen is an inert gas, but dissolved oxygen is a strong oxidizing agent. Dissolved oxygen is responsible for corrosion in water lines, boilers, and heat exchangers. Dissolved gases can be removed using various de-aeration methods including vacuum degasifiers and gas transfer membrane contactors. Oxygen can also be removed by an ion-exchange process or by chemical scavenger agents.

Chlorine gas (added for disinfection) reacts with water to form hypochlorite ion ( $\text{ClO}^-$ ) and hypochlorous acid ( $\text{HClO}$ ); the relative amounts of each depend on the pH of the water. Hypochlorous acid is the more effective disinfectant and it is formed at pH values less than 7.0. Free chlorine is also known to react with residual organic compounds to form trihalomethanes (THMs). Many purveyors of potable water are now adding ammonia gas with chlorine to form monochloramines ( $\text{NH}_2\text{Cl}$ ). Chloramines are not as effective as free chlorine for disinfection, but they minimize THM formation and are more stable and longer lasting than free chlorine. Chlorine and chloramines are effectively removed with

granular activated carbon or by injection of chemical reducing agents such as sodium bisulfite.

Hydrogen sulfide (H<sub>2</sub>S) is primarily found in well water supplies where anaerobic conditions or bacterial action reduce sulfate to sulfide. Hydrogen sulfide has a characteristic rotten egg smell. Various oxidation methods such as chlorine, ozone, or oxidizing filters can remove hydrogen sulfide.

### Particulate Matter

Suspended particulate matter in water may be inorganic or organic and includes colloidal silica, fine silt, organic acids, microorganisms, and other discrete dispersed matter. Generally, the small size prevents rapid settling, or the particles are dispersed by electrostatic surface charges. Turbidity is the term used to define this type of contamination.

Turbidity is measured using light scattering optical methods such as a Nephelometer. Turbidity is not an absolute measure of the concentration of particles, but it is a relative measure based on standard stabilized solutions of various suspensions such as formazin. Turbidity is removed using various filtration methods including multimedia filters, ultrafilters, sub-micron membrane filters, and reverse osmosis membranes.

Silt Density Index (SDI) is another measure of particulate matter, and the measured value reflects the rate of plugging of a 0.45 micron membrane filter disc by particles in the source water. The test is used to correlate the level of suspended solids in water that tends to foul reverse osmosis membranes. Most RO membrane manufacturers specify that the feedwater have SDI values less than 3.0.

### Microorganisms

Most bacteria found in purified water systems are *Pseudomonas* species. These bacteria are generally plant pathogens found in soil and water, but a few species are known to be human pathogens. They are highly motile (flagellated), live in an aerobic environment, and oxidize glucose for nutrients (heterotrophic). They are rod shaped single cell microorganisms about 0.5 microns in diameter and about 3 to 5 microns in length. They are opportunistic and can adapt and survive under severe conditions of extremely low concentrations of organic substrates such as in purified water systems. The slimy polysaccharide cell wall of the bacteria promotes adhesion to surfaces and biofilming occurs rapidly on any contact surface. The polysaccharide coating also traps nutrients and protects the cell from disinfectants such as chlorine.

Bacteria are quantified in terms of colony forming units per volume of water (CFU/ml or CFU/100 ml). Bacteria testing involves filtering a known volume of water through a sterile 0.45 micron membrane filter disc, incubating the filter disc on a nutrient pad at a standard temperature (35°C), and counting the colonies

formed on the filter disc after the prescribed incubation time (48 hours). Each colony is assumed to have grown from a single cell. This is termed the “standard plate count” method.

Since bacteria replicate rapidly under ideal conditions for growth, control of bacteria in a purified water system is one of the most difficult challenges. The best strategies include the following: provide complete recirculation at turbulent velocities (3 fps); use 254 nm ultraviolet in the loop; eliminate any piping dead-legs; use sanitary piping with low surface roughness; operate at sanitizing temperatures; or frequently flush and sanitize with hot water, ozone, or other chemical disinfectants. Even with these measures, biofilming can occur in ambient temperature systems and compromise the bacteriological quality of the water. An inexpensive, yet effective measure for controlling bacteria at the point of use is to install sterile 0.2 micron membrane filters on the water faucets or outlets.

## Endotoxins

*Endotoxins* are the polysaccharide compounds from the cell wall of certain bacteria such as those found in purified water systems. They are termed *pyrogenic* because they induce a fever response when injected in warm-blooded mammals and can even cause shock and death. They have two major components: a *hydrophilic* (water soluble) polysaccharide chain attached to a *hydrophobic* (insoluble in water) lipid (fatty) group. The hydrophobic portion causes endotoxins to aggregate together in vesicles ranging in size from about 20,000 daltons to millions of daltons. One molecular weight (MW) is about one dalton. Based on this, endotoxins can be removed using ultrafilter membranes in the 10,000 dalton pore size range or by using reverse osmosis membranes. Properly designed distillation systems also remove endotoxins.

Endotoxins are quantified in terms of Endotoxin Units per milliliter (EU/ml) using the Limulus Ameobocyte Lysate test (LAL). EU's are assigned by comparison with a USP reference endotoxin standard. Endotoxins react with the LAL (purified extract of the blood of the horseshoe crab) causing a turbid or clotting reaction that permits quantification to extremely low levels (about 0.001 EU/ml). The USP water for injection specification limit for endotoxin is less than 0.25 EU/ml.

## Water Quality Specifications

### Reagent Grade Water

Reagent grade water (RGW) is defined as water suitable for use in a specified procedure such that it does not interfere with the specificity, accuracy, and precision of the procedure. In addition, the water quality must meet the specifications established for the application. This definition applies to any high purity water application.

CAP, NCCLS, and ASTM have established RGW specifications for uses ranging from general laboratory to specific clinical laboratory applications. General laboratory applications include glassware washing and rinsing, chemical reagent and buffer solution preparation, making blanks and standards for calibrating analytical instrumentation, culture media, etc. Clinical laboratory applications include procedures in bacteriology, immunology, hematology, histology, etc. The NCCLS reagent grade water specifications are shown in Table 1, and the ASTM reagent grade water specifications are shown in Table 2.

Some applications may have “special” requirements beyond RGW specifications. For example, high performance liquid chromatography (HPLC) may require water with a maximum absorbance of a specified wavelength of ultraviolet light. Special “HPLC” grade water systems are offered by some companies, and some suppliers offer “HPLC” grade bottled water.

### *National Committee for Clinical Laboratory Standards (NCCLS)*

The NCCLS specifies three grades of RGW (Types I, II, and III). The NCCLS does not specify the acceptable methods of water purification for producing RGW; however, it does state that any method or combination of methods is acceptable as long as the product water meets the applicable specifications. Type I water is the highest quality and is generally used in more critical applications such as trace element analysis, automated analyzer systems, reagent and buffer solution preparation, etc. Type II water is used in general clinical methods including immunology, hematology, etc. Type III water is used for some qualitative procedures, glassware washing, etc.

The NCCLS specifies water sampling and testing methods for the parameters listed. Type I water quality must be measured using an inline resistivity sensor to avoid the problems associated with rapid absorption of atmospheric carbon dioxide into the deionized water. Rapid absorption of even small amounts of carbon dioxide into the water sample causes a significant drop in the resistivity of the water.

In addition, general water purification system design and maintenance guidelines are offered by NCCLS. It is suggested to use inert materials of construction to prevent leaching of inorganic and organic contaminants. Systems should be designed with complete recirculation avoiding dead-legs (stagnant areas). Outlet designs should minimize dead spaces and use non-leaching seal materials. It is generally not preferred to store and distribute pure water (Type I water can not be stored and remain Type I quality); it is suggested to produce final product water quality on demand at the point-of-use. Systems designed to store and distribute Types II and III water should be provided with measures to protect the chemical and microbial water quality (recirculation with 254 nm ultraviolet, sealed tanks with 0.2 micron hydrophobic vent filters, etc.). Sanitization of the system is recommended at least semi-annually or as necessary for quality control.

NCCLS, Type I water systems must include granular activated carbon treatment for organics and chlorine removal, mixed-bed deionization to meet resistivity and silica specifications, and 0.2 micron post-filtration for bacteria and particle control. Type II water can generally be produced by distillation, deionization, or reverse osmosis with polishing deionization or electrodeionization (EDI). Reverse osmosis technology is capable of providing Type III reagent grade water depending on the feedwater quality and the design and operation of the reverse osmosis system.

Table 1  
National Committee for Clinical Laboratory Standards  
Reagent Grade Water Specifications

Parameter	Type I	Type II	Type III
Bacteria, max. (CFU/ml)	10	1000	NS
pH, units	NS	NS	5 - 8
Resistivity, min. (megohm)	10	1.0	0.1
Silica, max. (mg/l)	0.05	0.1	1.0
Particles	0.22 micron filtration	NS	NS
Organics	carbon filtration	NS	NS

*The American Society for Testing and Materials (ASTM)*

The ASTM establishes specifications for Types I, II, III, and IV reagent grade water (D1193-99e1) as shown in Table 2. In addition, the water quality is further classified as Type A, Type B, or Type C depending on the applicable bacteriological and endotoxin quality. Type I water is the highest quality and is generally used for the most critical applications – trace element analysis, HPLC, reagent preparation, etc. The ASTM further specifies that Type I water is produced by mixed-bed deionization with suitable pretreatment (distillation or other equal process that can produce water with a maximum conductivity of 20 uS/cm) and post filtration with 0.2 micron membrane filters. Type I water quality can not be maintained in storage and must be produced on demand at the point-of-use. Resistivity can only be measured using inline resistivity monitoring equipment.

Type II reagent grade water is produced by distillation with suitable pretreatment (reverse osmosis or deionization) and, depending on the design of the storage tank, is generally sterile and *endotoxin-free*. This grade of water is suitable for preparing culture media, microbiology, bacteriology, etc. Care must be taken in the design of the storage tank and the distribution system to prevent bacterial contamination.

Type III reagent grade water is produced by distillation, deionization, reverse osmosis, electrodeionization, or a combination of these technologies, followed by post-filtration with a 0.45 micron membrane filter. This grade of water is generally suitable for preparing various reagents, qualitative analysis, etc. Design of storage tanks and distribution systems is critical to prevent contamination.

Type IV reagent grade water is produced by any of the primary treatment methods (distillation, deionization, electrodialysis, or reverse osmosis) or a combination of these methods. This water quality is generally used for glassware washing, cooling applications, etc.

Table 2  
American Society for Testing and Materials  
Reagent Grade Water Specifications

Parameter	Type I	Type II	Type III	Type IV
Resistivity, min. (megohm)	18.0	1.0	4.0	0.2
pH, units (25°C)	NA	NA	NA	5 – 8
TOC, max. (ug/l)	50	50	200	NS
Sodium, max. (ug/l)	1	5	10	50
Chloride, max. (ug/l)	1	5	10	50
Total Silica, max. (ug/l)	3	3	500	NA
	Type A	Type B	Type C	
Bacteria, max. (CFU/100 ml)	1	10	1000	
Endotoxin (EU/ml)	<0.03	0.25	NA	

## Pharmaceutical Grade Water

The United States Pharmacopoeia (USP 25) is the accepted guide (compendium) for producing pharmaceutical products in the US. The USP specifies standards of quality, purity, packaging, and labeling for many pharmaceutical products and the ingredients used in the manufacture of these products. The guide specifies two grades of bulk ingredient water used in the preparation of compendial dosage forms, USP purified water (PW) and USP water for injection (WFI).

The US Food and Drug Administration (FDA) provides a regulatory /enforcement function in the pharmaceutical industry. The FDA has established guidelines known as the Current Good Manufacturing Practices (CGMP) to regulate the industry. The CGMPs are essentially guidelines used by industry to establish comprehensive quality management plans to insure the safety of drug products. The CGMPs provide some guidelines that affect the design and operation of USP grade water systems. In addition, water systems must be validated systems; validation is a documented process that provides assurance that the system will remain in control and consistently provide the specified water quality.

### *USP Purified Water (PW)*

USP purified water is an ingredient in many pharmaceutical products. It is *not* applicable for the manufacture of parenteral (injectable) drugs and some other drug products. The USP specifies the following requirements for purified water:

- Produced by a suitable process – reverse osmosis, deionization, or distillation
- Produced from “drinking water” – meets EPA potable water standards
- Contains no added substances
- Meets the requirements of the Conductivity Test – less than 2.1  $\mu\text{S}/\text{cm}$  at 25°C, and 6.6 pH (varies depending on temperature and pH)
- Meets the requirements of the TOC Test – less than 500 PPB
- To control bacteria growth, USP suggests a microbial action limit of 100 CFU/ml

The FDA stipulates the following additional requirements for purified water:

- Free of “objectionable organisms” that can infect or grow in the product – the burden is on the manufacturer to determine the nature of this problem and establish applicable specifications
- Conformance with CGMPs

### *USP Water for Injection (WFI)*

USP water for injection (WFI) and sterile water for injection are used in the manufacture of parenteral drugs and other products such as ophthalmic and inhalation products. The USP specifies the following requirements for water for injection:

- Meets all of the requirements for purified water
- Produced by distillation or reverse osmosis
- Meets the requirements of the Bacterial Endotoxin Test – less than 0.25 EU/ml
- Suggested microbial action limit of 10 CFU/100ml
- Produced, stored, and distributed under conditions designed to prevent production of endotoxins

The FDA stipulates the following additional requirements for WFI:

- Reverse osmosis as a final means of production is discouraged, but if it is used, double-pass reverse osmosis is suggested
- Conformance with CGMPs

### *CGMP Compliance Issues*

Critical process parameters are those parameters that directly affect water quality and include conductivity, TOC, sanitizing temperature, etc. Because microbial quality and endotoxin quality cannot be monitored in real time, monitoring of parameters that affect these are considered critical and may include process temperature, UV intensity, ozone concentration, recirculation flow rate, loop pressure, etc. Instruments that measure these parameters are considered critical instruments, and these instruments must be properly calibrated on a regular basis and documentation must be maintained.

Regulatory compliance issues have more to do with establishing system design specifications and properly documenting the validation of the system. This includes verifying installation, operation, and performance qualifications; establishing sampling and testing protocols; materials verification documentation; establishing sanitization protocols; record keeping; etc.

The critical concern in the design of pharmaceutical water systems is to avoid designs that could compromise bacterial and endotoxin quality. CGMP design strategies to control bacterial and endotoxin quality include the following:

- Provide continuous recirculation at turbulent flows (3 fps in the return line)
- Eliminate piping dead-legs and use zero dead-leg outlet valves
- Establish standard operating procedures (SOP) for frequent draining, flushing, and sanitizing
- Maintain positive system pressure

- Adhere to accepted backflow prevention practice
- Design for complete system drainability (WFI systems)
- Provide smooth, inert surfaces and joints (180 grit minimum)
- Store and distribute WFI quality water at 80° to 90°C

## General Design Considerations

It is important to establish the appropriate water quality specifications for the given application. If specific regulatory or industry standards do not exist, the user is responsible for establishing the applicable water quality specifications.

It is generally impractical to design individual water systems to provide specific water quality for each application in a large facility. If the most critical application requires the bulk of the water usage, it is common to design a system to meet the requirements of the most critical application and supply this quality of water to all applications. However, if the critical application requires minimal water usage in comparison to other less critical applications, providing point-of-use polishing systems to meet the needs of the most critical applications may be the most practical option. Economic considerations generally dictate the design of the water system.

The design of the water system may be influenced by the applicable water quality specifications. For example, ASTM and USP specify the method of production for the various types of water quality. ASTM, Type I reagent grade water must be produced by distillation or an equivalent process (RO or deionization) which can produce water with a maximum conductivity of 20 uS/cm (minimum of 50,000 ohm-cm resistivity). This must be followed by a mixed-bed deionization system capable of providing water with 0.055 uS/cm conductivity (18 megohm-cm resistivity). Further, the deionized water must be post-filtered with a 0.2 micron membrane filter. A sterile 0.2 micron, absolute rated membrane filter cartridge can produce bacteria-free water.

A water system designed to provide ASTM, Type I reagent grade water for a small laboratory consists of a number of *integrated* components. A pre-filter cartridge (0.2 to 0.5 micron pore size rating) provides for removal of particulate matter. A granular activated carbon filter removes chlorine and organics. A primary mixed-bed deionizer provides TDS removal to a maximum of 20 uS/cm conductivity, and a polishing mixed-bed deionizer provides 0.055 uS/cm conductivity final water quality. In addition, the system may include an in-line conductivity sensor and monitor, water dispensing faucet with a 0.2 micron post-filter capsule, and a recirculation pump (Figure 1).

Optional components could include a 185 nm ultraviolet system installed before the polishing deionizer to provide for trace organics removal (TOC less than 10 PPB), an ultrafilter membrane for endotoxin removal, and a 254 nm ultraviolet unit for bacteria control.

For greatly improved water quality and economy of operation (especially for higher capacity systems), a reverse osmosis system and a water storage tank with a booster pump station can be used in lieu of the primary deionizer unit. Reverse osmosis is a membrane separation process that filters the water through a membrane with pore sizes less than 0.001 micron and can provide greater than 98 percent rejection of TDS. The throughput of polishing mixed-bed deionizers can be increased by as much as 6 to 8 times by using reverse osmosis for primary water treatment. For many small laboratory systems the capital cost payback can be as short as a few months.

Large central systems designed to provide ASTM, Type I reagent grade water generally include a reverse osmosis system for primary treatment, storage tank with water distribution pump station, polishing mixed-bed deionization, 0.2 micron post-filter, and a recirculated piping system (Figure 2). An optional 254 nm ultraviolet system may be installed after the post-filter for control of bacteriological quality.

Applicable pretreatment for reverse osmosis systems depends on the feed water quality and may include a turbidity filter, carbon filter for chlorine removal, softening system for hardness removal, and a 5 micron disposable cartridge prefilter. Pretreatment is critical to optimize the performance and the life of the reverse osmosis membranes.

One of the most difficult problems in the design of large central water systems providing ASTM, Type I water quality is maintaining Type I water quality at every point-of-use location in a complex water distribution system. The design of the water distribution system is critical to maintaining water quality. Low velocity or stagnant areas in the piping system, leaching of contaminants from the piping materials, bacteriological activity, and intrusion of carbon dioxide in the water can rapidly degrade water quality. An alternative is to design a central water system to provide ASTM, Type III water quality or NCCLS, Type II water quality and install polishing mixed-bed deionization systems at critical points-of-use where Type I water quality is required.

ASTM, Type III and Type IV reagent grade water must be produced by distillation, mixed-bed deionization, or electrodeionization (EDI) to meet the sodium and chloride specifications. A typical system may consist of reverse osmosis for primary treatment (with applicable pretreatment equipment) followed by mixed-bed deionization or EDI, water storage tank, booster pump station, and a recirculated piping system. To consistently meet the resistivity specification for ASTM, Type III water, polishing deionization may be required after the storage tank. Alternatively, a nitrogen blanketing system on the storage tank to prevent the absorption of carbon dioxide may be required to prevent degradation of the resistivity of the stored water. Applications with minimal water usage requirements are often served with exchangeable mixed-bed deionizers, even though the water quality may be better than needed.

Other integrated system design options can be used, but a thorough knowledge of the feed water quality, water quality objectives, and water system process design is needed to provide a suitable system.

Common practice in high purity water system design for pharmaceutical and biotechnology applications is to store the final product water (PW or WFI) before distribution to the points-of-use. This practice facilitates frequent sanitization of the system or allows for storage and distribution of the water at sanitizing temperatures (90°C) which is common in WFI systems.

Many combinations of unit processes can be used to produce USP purified water. Final treatment options include distillation, mixed-bed deionization, double-pass reverse osmosis, reverse osmosis followed by polishing mixed-bed deionization, and reverse osmosis followed by EDI.

The most common USP purified water system design consists of an RO system for primary water treatment (with applicable pretreatment equipment), polishing mixed-bed deionization, 0.2 micron post-filter, 254nm ultraviolet system, USP water storage tank, booster pump station, and recirculated distribution piping system (Figure 3).

Other common process design configurations include the following:

- Pretreatment, RO primary treatment, EDI polishing treatment, 0.2 micron post-filter, 254nm ultraviolet, storage, and distribution
- Pretreatment, RO primary treatment, storage, booster pump, distillation (vapor compression or multi-effect), storage, and distribution

In systems designed for hot water or steam sanitization, the tank, booster pump, heat exchanger, and piping system are constructed of sanitary, 316L stainless steel. The storage tanks used in these systems are ASME pressure vessels constructed of polished, 316L stainless steel and rated for vacuum and pressure applications at temperatures above the maximum operating temperature of the system. These pressure vessels are also equipped with sanitary fittings, 0.2 micron absolute rated hydrophobic vent filter, pressure/vacuum rupture disc, internal spray ball on the recirculation return line, level and temperature controls, and insulation.

Other design considerations include sizing of equipment items to meet capacity and peak usage demands, utility requirements, space availability and access, instrumentation and control requirements, maintenance requirements, and future needs. Budget considerations may also influence system design options. In some cases, the cost of the high purity water system can be a significant percentage of total process system cost. Other significant costs could include system validation, quality control, and wastewater treatment.

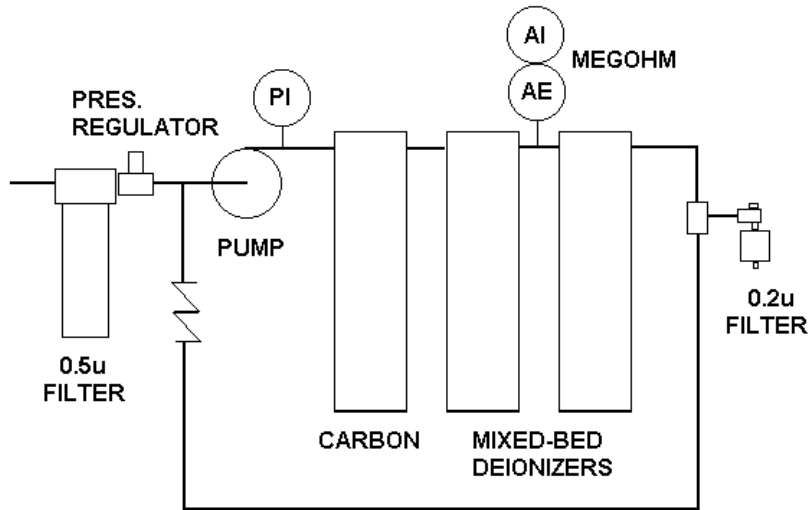

**FIG. 1 - LABORATORY TYPE I REAGENT GRADE SYSTEM**

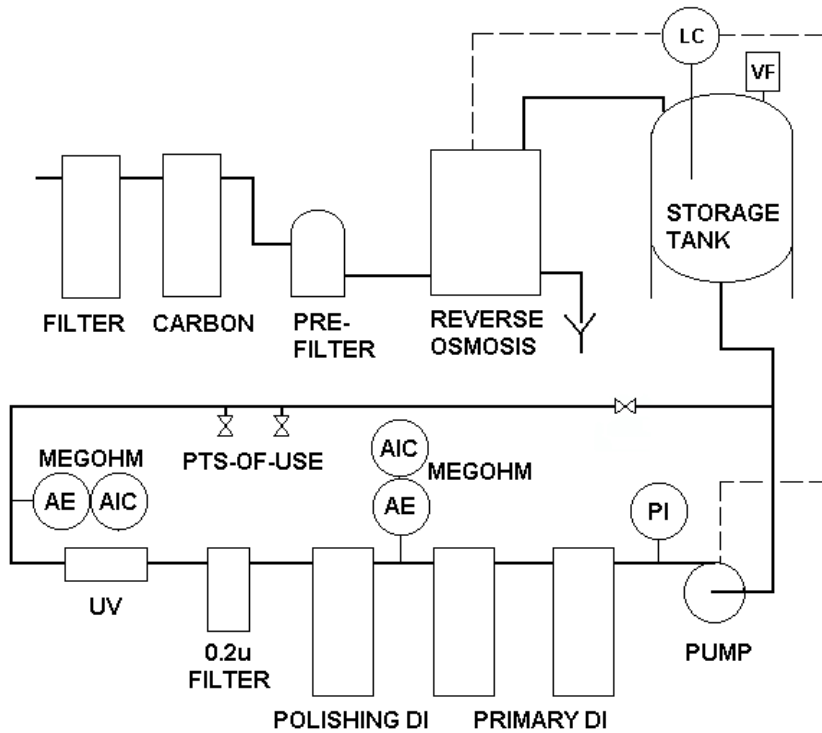

**FIG.2 - CENTRAL WATER SYSTEM ASTM TYPE I**

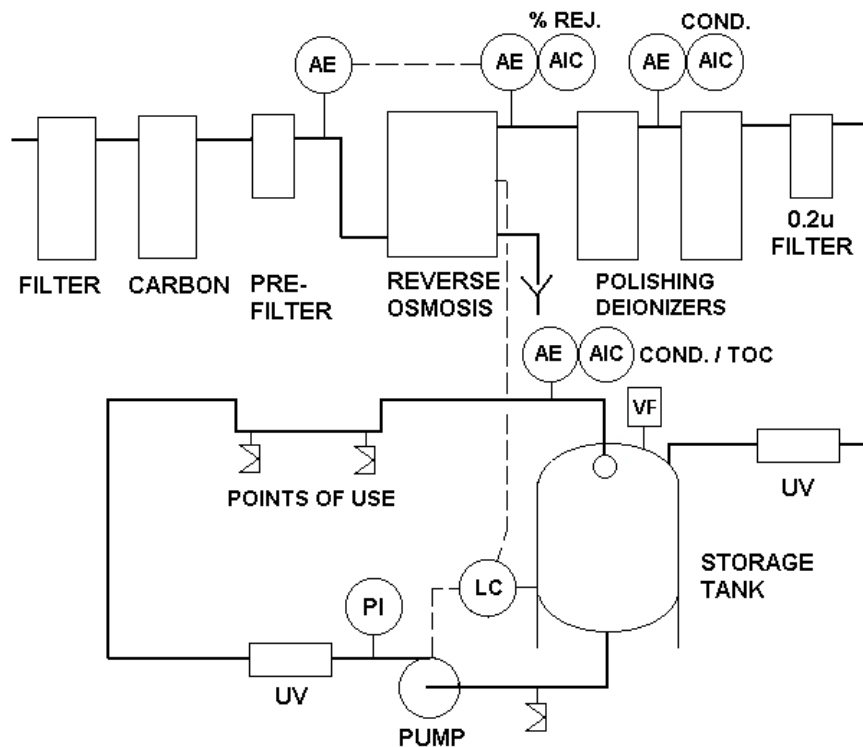

**FIG. 3 - USP PURIFIED WATER SYSTEM**

## References

1. National Committee for Clinical Laboratory Standards, NCCLS C3-A2, "Preparation and Testing of Reagent Water in the Clinical Laboratory; Approved Guideline", Third Edition, Vol. 17 No. 18, October 1997.
2. American Society for Testing and Materials, ASTM D1193-99e1, "Standard Specification for Reagent Grade Water", *Annual Book of ASTM Standards*, Volume 11.01, American Society for Testing and Materials, Philadelphia, PA (2003).
3. Meltzer, Theodore H., *High Purity Water Preparation for the Semiconductor, Pharmaceutical, and Power Industries*, Tall Oaks Publishing, Inc., Littleton, CO (1993).
4. International Society for Pharmaceutical Engineers, *Baseline Pharmaceutical Engineering Guides for New and Renovated Facilities, Water and Steam Systems*, Vol. 4, First Edition, January 2001.
5. Winstead, Martha. *Reagent Water: How, When, and Why?*. The American Society of Medical Technologists, Houston, TX (1967).
6. Murphy, Daniel B., and Viateur Rousseau. *Foundations of College Chemistry*. New York: The Ronald Press Company (1969).